

moduhub Module Combinations For Handling Technology

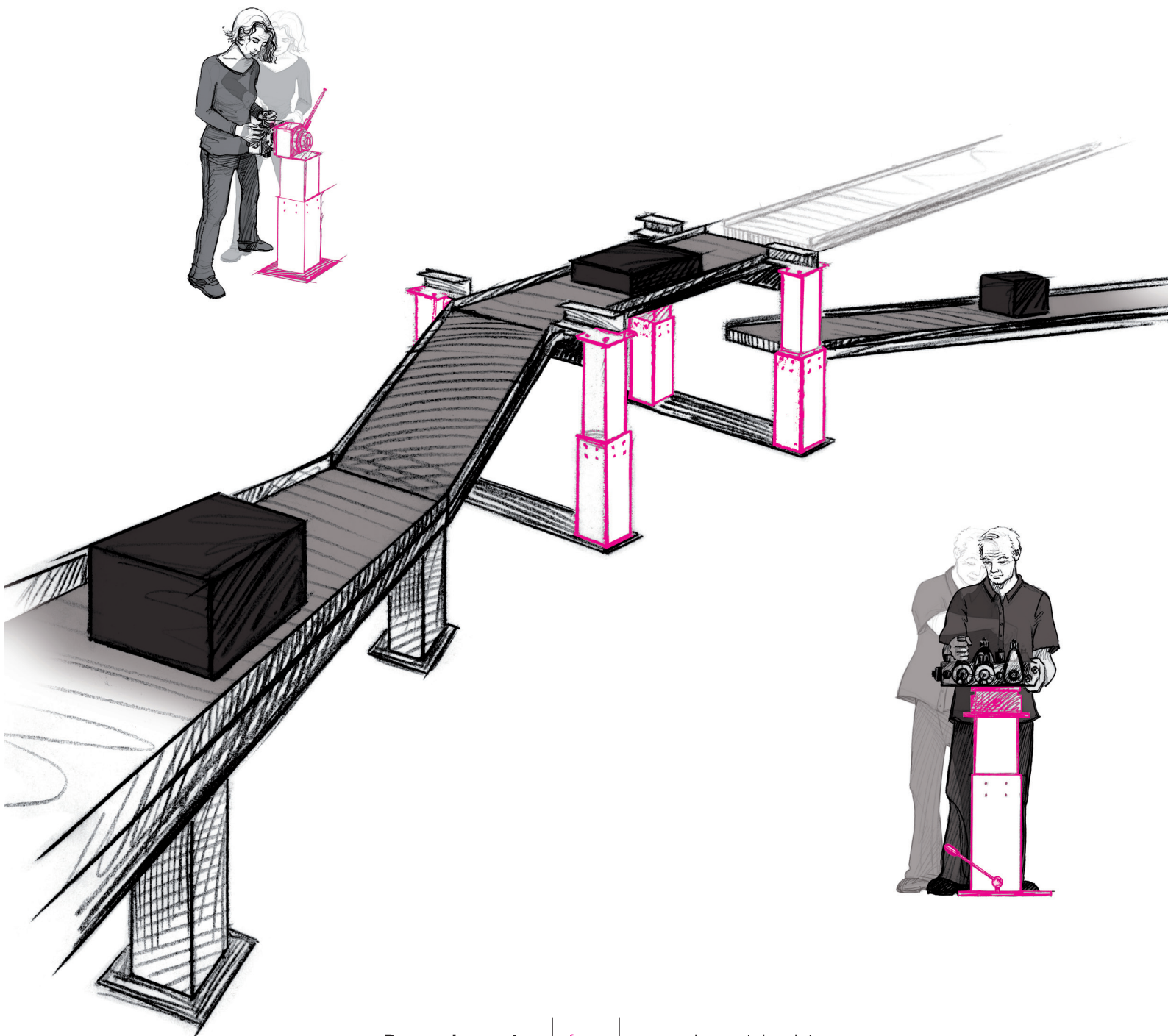



Easy handling of heavy loads – more productivity

Handling and manual assembly of heavy loads offer a high potential for rationalisation.

Using the *moduhub* modules and module combinations easy handling and assembly is always assured in the optimum position. Quality and productivity of the assembly operations will be enhanced and the throughput of ready assembled subassemblies in the production will be increased.

The *moduhub* modules can be combined suitably for very different and individual assembly tasks.

High flexibility is guaranteed, due to the modular design adaptation or retrofitting for further assembly tasks is easily possible.



Electric height-adjustable working table

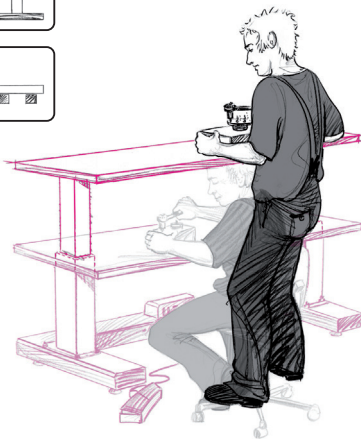

Height-adjustable working tables provide at the work station an optimum working height individually adjustable by the operator.

The electric height adjustment of both lifting modules is made in synchronism, operated by an easily operated foot panel.

High stability provides a floor module, on which both lifting modules are mounted.



Lifting module operated by foot pedal with rotating module vertical axis

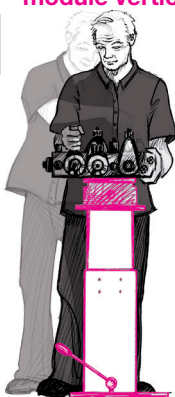

For manual assembly of complex hydraulic subassemblies, components have to be mounted from five sides into the hydraulic block.

The employee rotates the required side by hand to himself and indexes the assembly position.

The appropriate working height is adjusted by the foot pedal of the hydraulic lifting module.



Lifting module operated by hand panel with rotating module horizontal axis



For manual assembly in multi-shift operation, every employee adjusts the desired assembly height individually by means of the hand panel of the electric lifting module.

By means of the hand lever of the rotating module horizontal, the component is rotated by 90° at a time and indexed in that position, so that the components can be easily mounted from the top into the body.

moduhub Module Programme for Handling Technology

A high degree of ergonomics – Safety for persons and processes

For manual assembly processes the subassemblies and components to be assembled have to be brought to the most favourable position. Ergonomic handling of the components plays a decisive role.

Using the *moduhub* modules and module combinations, all demands on ergonomics are met. Physical load and tiredness of the assembly employees are reduced to a minimum.

Motivation and efficiency are improved. The risk of accidents is reduced and down times decreased.

In addition, the processes of assembly and handling operations become safer and the quality of the products improves.



Electrically-operated lifting modules in synchronism

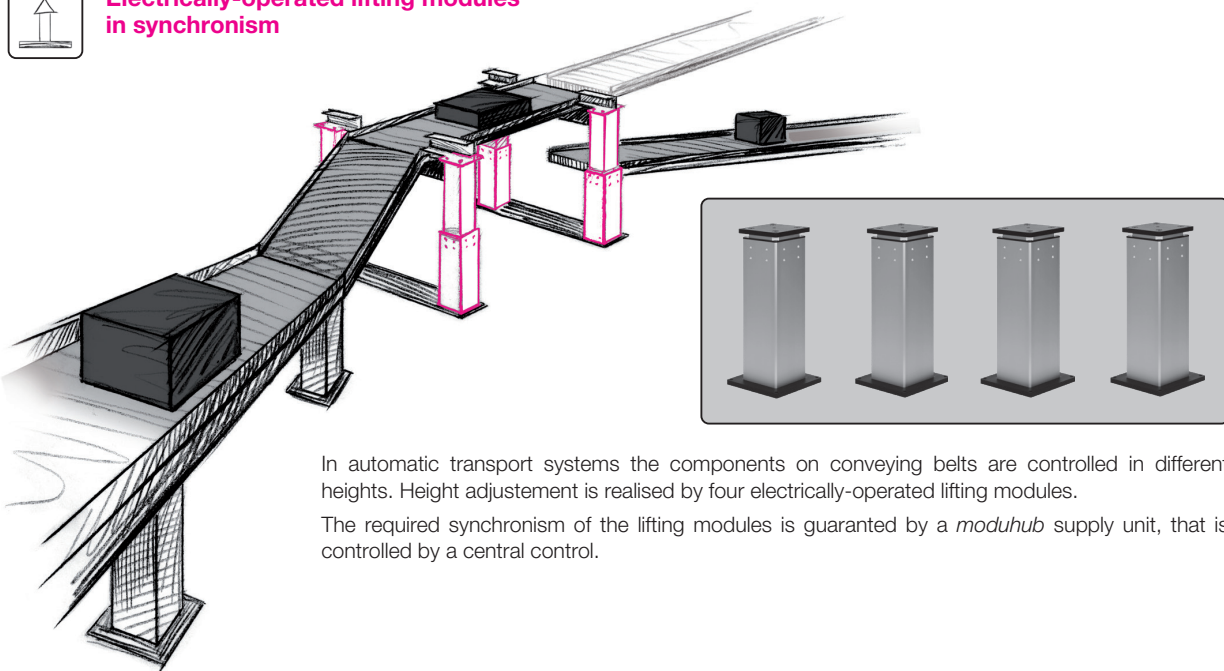

In automatic transport systems the components on conveying belts are controlled in different heights. Height adjustment is realised by four electrically-operated lifting modules.

The required synchronism of the lifting modules is guaranteed by a *moduhub* supply unit, that is controlled by a central control.



Lifting cart operated by foot pedal

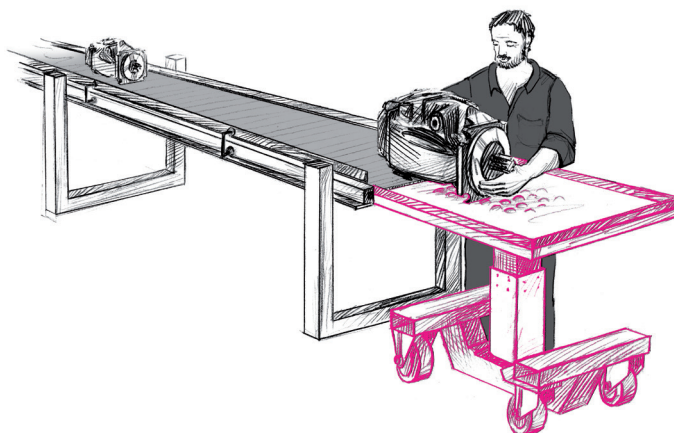

For assembly of heavy units for axial piston machines, the components are assembled at different working places. Assembly and different test processes are made at further working places.

For in-house transport, hydraulic lifting modules with table plates mounted on cart modules are used. The different heights of the working places are easily compensated by the lifting module with foot pedal operation.



Consultation and know how guarantee optimum use

With the *moduhub* module programme not only solutions for the manual assembly but also special solutions for semi or fully automatic systems can be realised according to the respective requirements.

Our comprehensive process know how and long experience are at your disposal to combine a suitable module combination for your individual application.

Incorporate the latest ergonomic knowledge in the planing of every system from the beginning.

Our competent consulting service supports you to realise considerable time and thereby cost savings. Use the ROEMHELD know how for your processes!

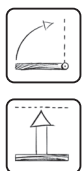

Lifting module operated by foot pedal with tilting module

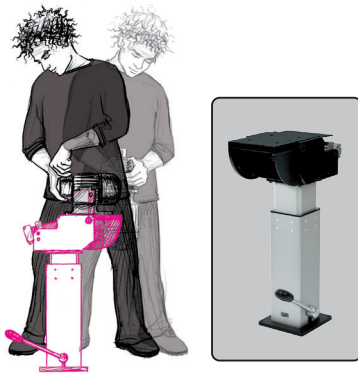

For the final assembly of electric motors connecting components and covers are mounted and several tests are effected.

The individual working height is adjusted by the foot pedal of the hydraulic lifting module, during assembly the motor is manually tilted back and forth by 90° nearly without force by means of a tilting module.



Lifting module operated by foot pedal with tilting module and rotating module vertical axis



For an optimum assembly of car seats, the seat has to be moved quickly to different positions.

All required positions are easily and quickly adjusted and fixed by the assembly employee by means of a hydraulic lifting module with mounted tilting module and rotating module vertical.



Electrically-operated lifting modules in synchronism

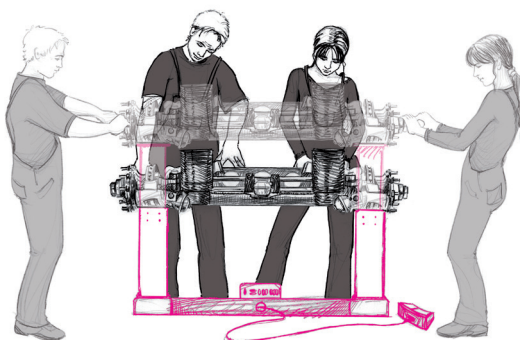

For the assembly of lorry axes, assembly operations are effected by two employees at the same time. Components are mounted from above as well as at both head sides.

The required working height is adjusted by a foot panel, that controls two electric lifting modules in synchronism. To improve the stability the lifting modules are mounted on a floor module.



The *moduhub* Module Principle

Module combinations – ideal for individual applications

The *moduhub* module system consists of individual modules which realise a basic function for the handling of workpieces. Modules for horizontal and vertical rotating, tilting as well as lifting of workpieces are available. This range is completed by cart and floor modules for movement and installation of the units.

All modules are complete functional units that can be easily combined to build multi-functional units. Thus there are various possibilities to use a system adapted to the corresponding demands without high costs for expensive special designs.

The modules



Rotating module horizontal axis

For rotation of the workpiece around the horizontal axis. Rotation will be effected directly at the workpiece or by means of a hand lever at the rotating module. Optionally, an indexing for the rotating positions of 4 x 90° is available. For workpiece weights up to 200 kg.



Tilting module

For tilting or swivelling of the workpiece around a defined axis between the final positions 0° and 90°. Tilting of a workpiece is made manually, the weight of the workpiece will be balanced. The standard versions are equipped with an indexing in the final positions 0° and 90°. For workpiece weights up to 100 kg.



Rotating module vertical axis

For rotation of the workpiece around the vertical axis. Rotation of the workpiece is made directly at the workpiece. The standard versions are equipped with an indexing of the rotating positions of 4 x 90°. For workpiece weights up to 1,000 kg.



Lifting modules

For guided lifting and lowering of the workpiece. The lifting movement is effected power-supported by a hydraulic or electrical actuator against the weight of the workpiece. The lowering movement is a defined lowering by use of the weight. For maximum workpiece weights of 100 to 1,000 kg. Maximum strokes from 200 to 940 mm.



Cart modules

Cart modules offer the possibility to move manually individual modules or module combinations with or without workpieces. All cart modules are equipped with a parking brake.

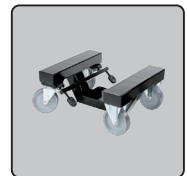

Floor modules

Floor modules compensate unevennesses of the floor place and offer a high stability. The offer includes two versions with one or two mounting plates for mounting of other *moduhub* modules.

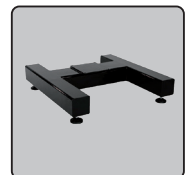



Worldwide Competence

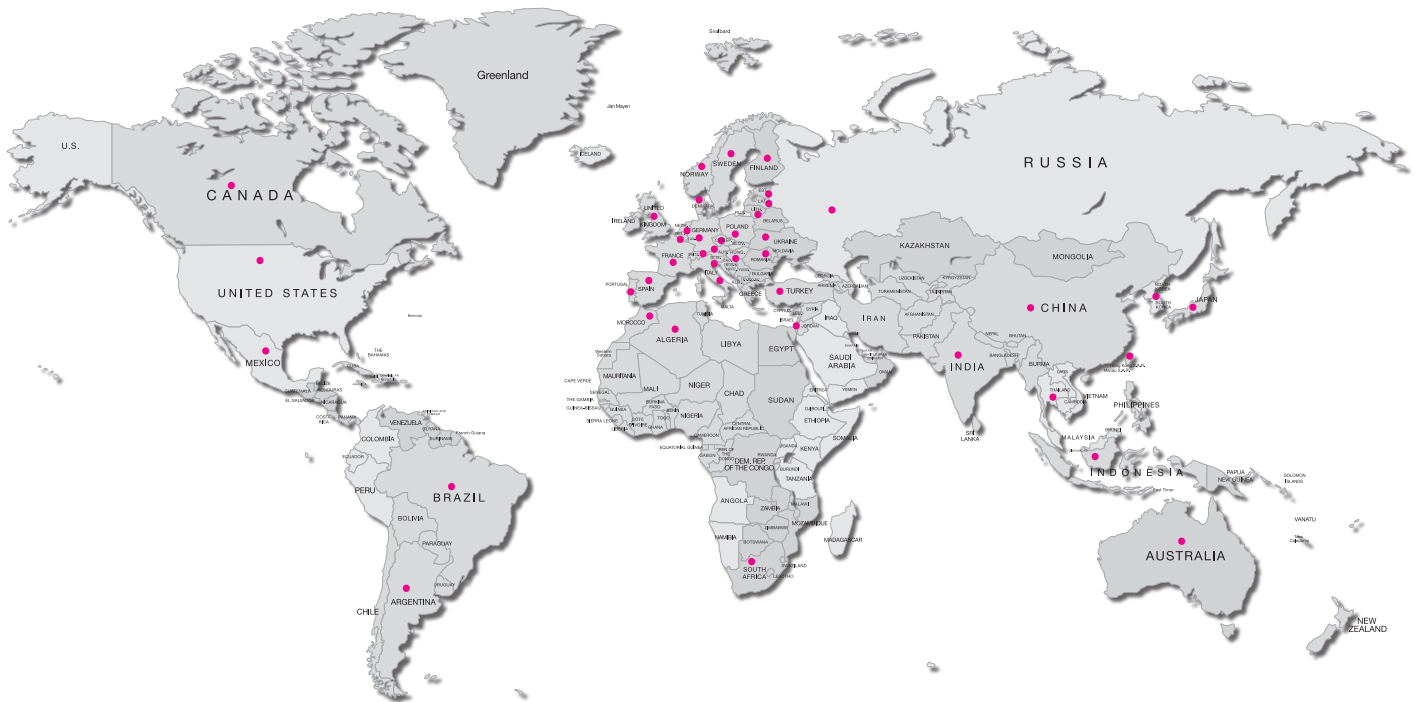

Römheld GmbH
Friedrichshütte
Römheldstraße 1-5
35321 Laubach
Germany

Tel.: +49 (0) 6405/89-0
E-mail: info@roemheld.de
www.roemheld.com