

Swing sink clamp double-acting for external clamping



HILMA



For power units,
please see product group 7

For accessories,
please see product group 11

Applications:

- for direct fastening to a press bed and a press slide
- when the available space is limited

Design:

Double-acting swing sink clamp with 90° swing cycle. The piston is guided by a guide pin in such a way that during the stroke a 45° rotation is carried out. For clamping, the tie rod is rotated by 90° from the unclamping position and pulled against the clamping surface through the existing clamping slots.

The unclamping, change-over and clamping position are monitored by inductive proximity switches. The swing mechanism is protected by a springloaded overload safety device and equipped with manual emergency operation.

Special features:

- ◇ very suitable for retrofit
- ◇ ideal power transmission
- ◇ compact design
- ◇ high functional reliability ensured by position monitoring, manual emergency operation and overload safety device
- ◇ suitable for large clamping edge tolerances (± 1.5 mm)
- ◇ optimum utilisation of bed and slide surface so there are no parts protruding when inserting the die
- ◇ die clamping even in barely accessible positions
- ◇ tie rod available up to a length of 2000 mm



Swing sink clamp double-acting for external clamping

Clamping force at 400 bar (kN)	104	216
100 bar (kN)	26	54
Piston-Ø e (mm)	70	100
Rod-Ø d (mm)	40	56
Max. clamping edge height (mm)	68	68
Swivelling stroke (i) (mm)	15	23
Clamping and lowering stroke (h) (mm)	105	112
Oil consumption clamping (cm ³)	514	1211
Oil consumption unclamping (cm ³)	388	948
Max. volume flow (cm ³ /s)	50	120
a (mm)	170	212
b (mm)	240	270
c (mm)	104	146
f (mm)	M27x1,5	M36x2
g	G 3/8	G 1/2
j	G 1/4	G 1/4
k (mm)	42	55
l (mm)	50	71
m (mm)	38	57
n (mm)	25	34
o (mm)	39,8	62
p (mm)	14	18
q (mm)	17,3	27,6
r (mm)	62,5	84
s (mm)	104	146
t (mm)	10	23
u (mm)	40	50
v (mm)	60	65
w (mm)	16,7	27,6
x (mm)	22,6	22,6
y (mm)	4,2	0
z (mm)	24	31
SW (mm)	14	22
Weight (kg)	16,5	35
without check valve Part no.	2235 310	2237 310
with check valve pilot controlled Part no.	2235 410	2237 410

Max. operating pressure: 400 bar
Other sizes and special designs are available on request

Tie rod dimensions

Swing sink clamp	2235-XXX			2237-XXX			
F1 clamping slot in the die (mm)	32	40	45	50	45	50	60
a1 (mm)	22	22	22	22	32	32	32
b1 (mm)	28	28	28	28	40	40	40
c1 (mm)	54	62	67	72	77	82	92
d1 (mm)	28	28	28	28	40	40	40
e1 (mm)	30	30	30	30	37	37	37

When ordering, please specify the dimensions A (slide plate), B (die clamping edge thickness) and F1 (clamping slot)

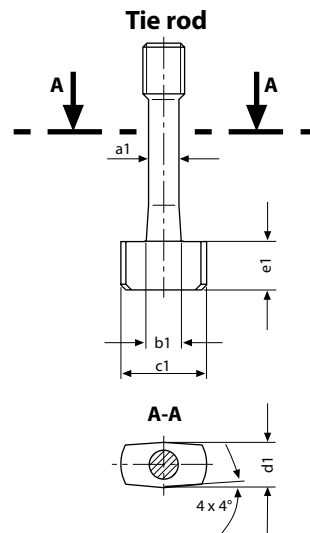
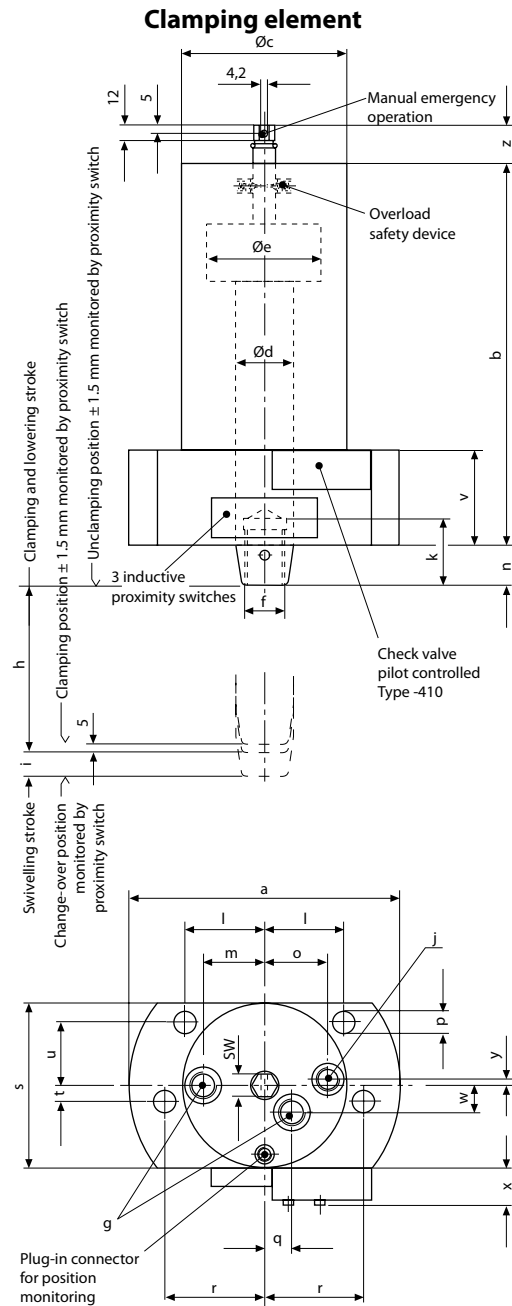
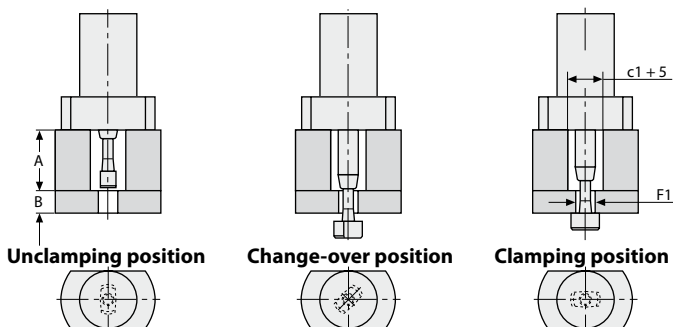

Swing sink clamp double-acting for external clamping



HILMA

Functional description

The piston of the double-acting swing sink clamp is guided by a guide pin in such a way that during part of the stroke a 45° rotation is carried out just before reaching or after leaving the upper piston end position. Rotation is always to the left regardless of whether the piston is retracting or extending.

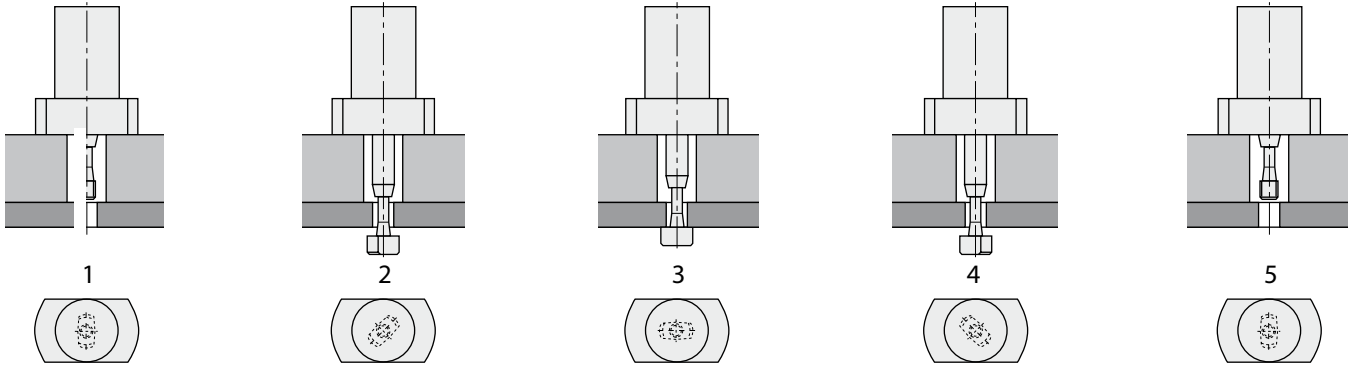

1. Unclamping position

The piston has completely retracted. Easy die change, as there are no parts protruding above bed or slide level.

2. Change-over position for clamping

Pressure is applied to piston side B. The tie rod has passed through the slot of the clamping point and has then rotated by 45°.

3. Clamping position

Pressure is applied to rod side A. The tie rod has rotated by another 45° and is now in a transverse position in relation to the clamping point. *The die is clamped.* Proximity switch 253 monitors this position.

4. Change-over position for unclamping

Pressure is applied to piston side B. The tie rod has extended and has rotated by another 45°. Proximity switch 252 monitors this position.

5. Unclamping position

Pressure is applied to rod side A. After having carried out another 45° rotation, the tie rod has passed through the slot of the clamping point and then to the end position. Proximity switch 251 monitors this position. *The die is unclamped.*

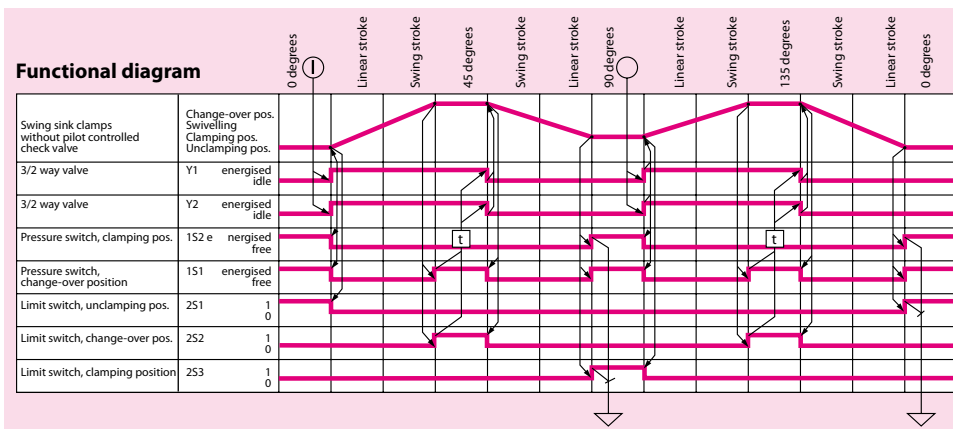

Hydraulic diagram without check valve

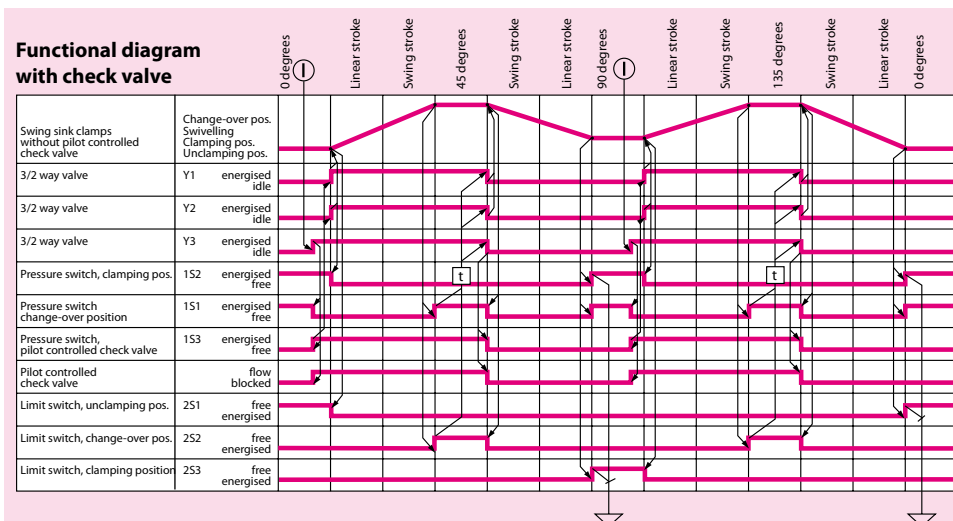
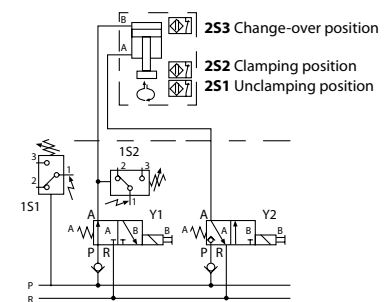

Hydraulic diagram with check valve

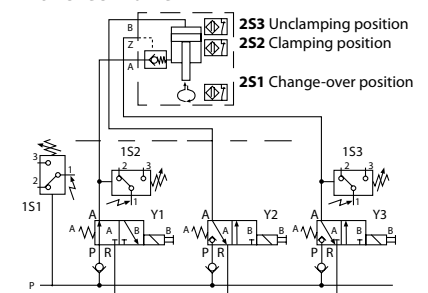



Swing sink clamp double-acting for external clamping

Electrical installation

Pin assignment for three-wire proximity switches

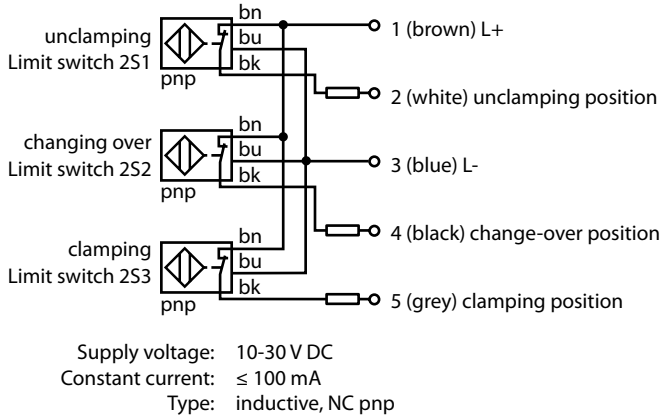

5-pole connecting lead with screw coupling

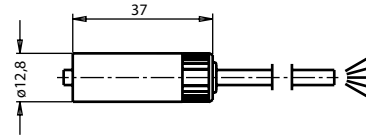

Cable length 5 m	Part no.	5700-013
Cable length 10 m	Part no.	5700-014

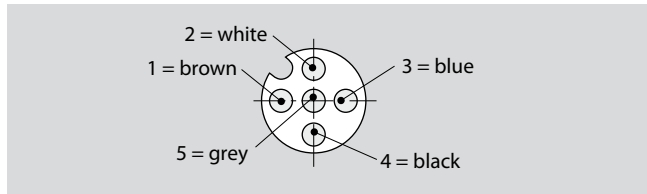

Distribution block with LED display for connecting 4 clamping elements

Easy installation!
LED display of the unclamping, change-over
and clamping position of each clamping element.
Scope of delivery: 1 distribution block
4 coupler plugs, 5 poles
1 coupler plug, 16 poles

Wiring of output plug:

- Pin 1 = L+
- Pin 2 = L
- Pin 3 = 1L
- Pin 4 = 1U
- Pin 5 = 1S
- Pin 6 = 2L
- Pin 7 = 2U
- Pin 8 = 2S
- Pin 9 = 3L
- Pin 10 = 3U
- Pin 11 = 3S
- Pin 12 = 4L
- Pin 13 = 4U
- Pin 14 = 4S
- Pin 15 = free
- Pin 16 = free

L = Unclamping position
U = Change-over position
S = Clamping position

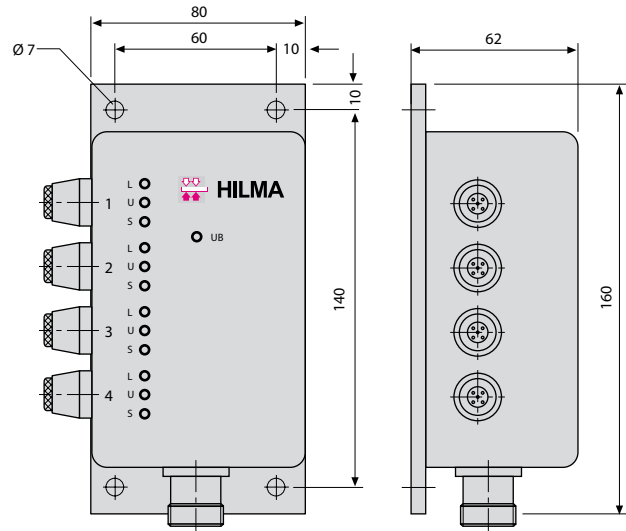

Part no.	5700-015
-----------------	-----------------

Hydraulic installation

Read the operating instructions before commissioning the system.

Adjust the displacement of the power unit so that clamping and unclamping cycles between 10 and 30 seconds are obtained. In order to prevent the swing mechanism from premature wear, the dynamic pressure at port B should not exceed 50 bar while the tie rods retract through the slot. Swing sink clamps which are grouped together should be connected to distribution blocks, in order to avoid series connection. Use pipes with larger diameter for connection to the power unit.

If in doubt, please send the installation plan to be reviewed.

Provide a pressure gauge connection in every hydraulic circuit for adjustment and to check operational data. Other parameters and recommendations for hydraulic installation of die clamping systems, are given in chapter no. 1 "General information".

Please note:

The full stroke of the piston must be realised, otherwise the swing mechanism may be damaged.