

# Swivel and pull clamp double-acting

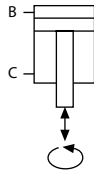

# HILMA



### Applications:

- for presses and high-speed punching presses
- when the available space is limited

### Design:

Swivel and pull clamping element double-acting with 90° swivelling angle. The clamping element consists of a hollow piston cylinder and a swivel cylinder. The clamping bolt held in the hollow piston cylinder is provided with teeth which engage in the toothed rack of the swivel cylinder. The clamping position is pneumatically monitored. Optionally, monitoring is also possible by inductive proximity switches.

### Special features:

- ◆ very suitable for retrofit
- ◆ ideal power transmission
- ◆ compact design
- ◆ optimum utilisation of bed and slide surface as there are no parts protruding when inserting the die
- ◆ die clamping even in barely accessible positions

### Tie rod retracted Swivelling angle 0°

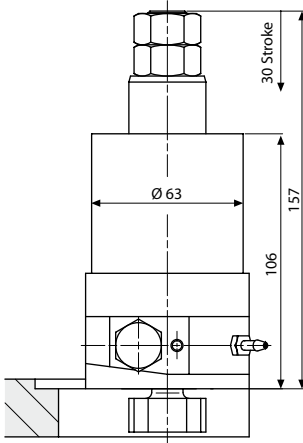

### Tie rod extended Swivelling angle 90°

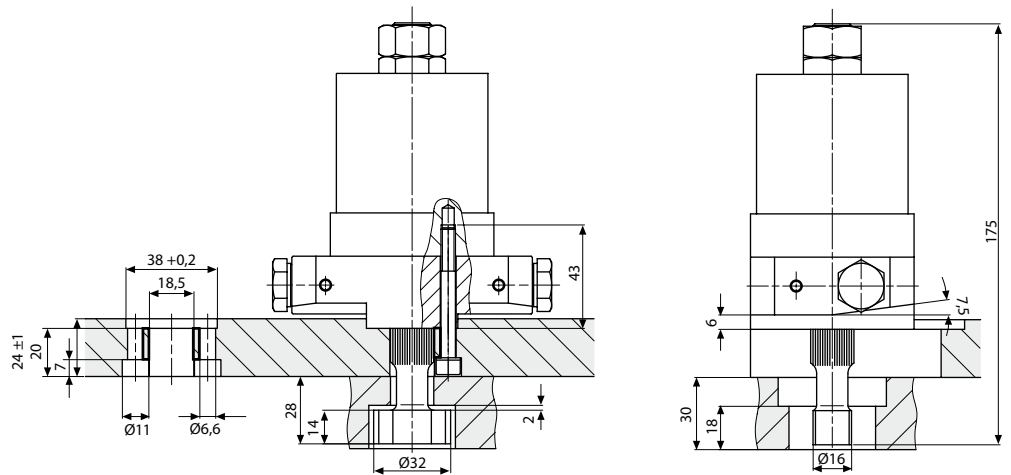

### Connections:

- A: Swivelling
- B: Extending
- C: Retracting / clamping

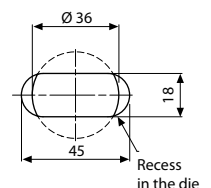
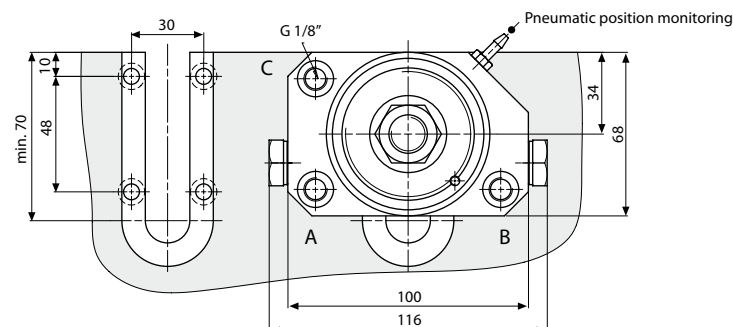

Subject to technical modification

**Hilma-Römheld GmbH**

Schützenstraße 74 · D-57271 Hilchenbach  
Phone +49 (0) 2733 / 281-0 · Fax +49 (0) 2733 / 281-113 · www.hilma.de

# 2.1833

10/2008



## Swivel and pull clamp double-acting

<b>Clamping force 400 bar (kN)</b>	<b>30,4</b>
Max. operating pressure (bar)	400
Stroke (mm)	30
Max. volume flow (cm <sup>3</sup> /s)	15
Oil consumption retract. (cm <sup>3</sup> )	24
Oil consumption extend. (cm <sup>3</sup> )	15
Weight (kg)	3,2
<b>with pneumatic position monitoring for the clamping position Part no.</b>	<b>1833-010</b>
<b>with inductive position monitoring Part no.</b>	<b>1833-013</b>

### Hydraulic diagram

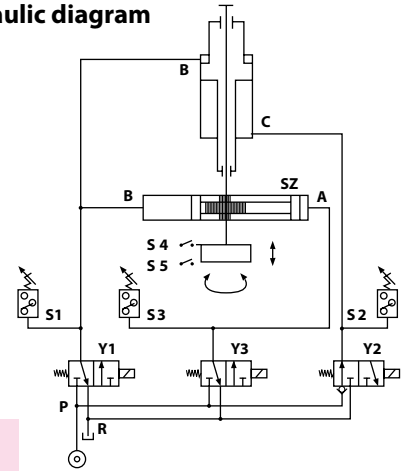

### Functional diagram

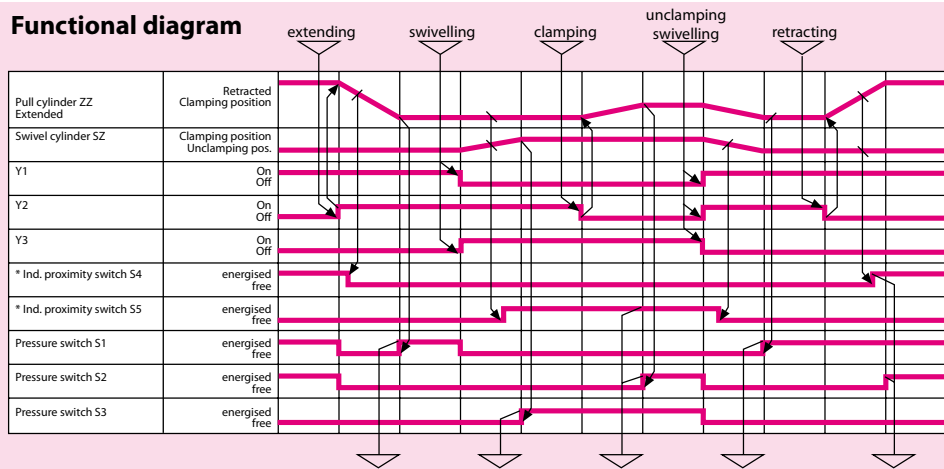

### Control

The valve control is shown in the hydraulic diagram. The valves have different initial positions, in order to avoid pressure drop during clamping in case of power failure. This is ensured by the check valve in the P-port of Y2.

### Important!

The P-port of valve Y1 must not be provided with a check valve, as during retraction pressure is applied to the piston from both sides (differential system).

Otherwise, due to the different piston areas, the pressure may be intensified and thus exceed the permissible operating pressure.

### Starting up

It is very important to completely bleed all lines.

Proceed as follows: adjust a low pressure on the power unit (20 - 50 bar). Start with the most distant swivel and pull clamping element, unscrew the lock nut and keep the power unit operating until the emerging oil is free from bubbles. Repeat this procedure at each port.

After bleeding, retighten all screws. Adjust the defined operating pressure (see hydraulic diagram) on the power unit (see operating manual). Prior to clamping a die, the functional sequence should be checked in accordance with the functional diagram.

**Position monitoring, however, can only be checked with the die clamped.**

### Functional sequence according to operational diagram:

1. Retracted position.  
Y1 is energised, Y2 and Y3 are de-energised, pressure is applied to cylinder ports B and C.
2. Extending  
When Y3 is energised, the pressure applied to C drops, the swivel and pull clamping element extends.

3. Swivelling  
Y1 is de-energised, Y3 is energised, pressure is applied to A only, the clamping bolt swivels by 90°.
4. Clamping  
Y2 is de-energised, pressure is applied to A and C, the element retracts with the clamping bolt swivelled.
5. Extending, unclamping, swivelling  
Y1 and Y2 are energised, Y3 is de-energised, pressure is applied to B only, the clamping bolt extends and swivels back by 90°
6. Retracting  
Y2 is deenergised. pressure is applied to B and C. Due to the larger piston area of C, the element retracts.

### Replacement of the clamping bolt

If it is necessary to disassemble the clamping bolt, it is very important that assembly of the replacement part is made in the same toothing position.

The counternuts have a tightening torque of 210 Nm. Make sure that there is still sufficient axial play for an easy turning of the clamping bolt (0.1 - 0.3 mm).

### \* Position monitoring (on request)

By means of the position monitoring system pneumatic or inductive control of both the clamping and unclamping position is possible.

Pneumatic position monitoring is made by a nozzle which is closed in the corresponding position. The position signal is generated by a pneumatic flow switch. Data sheets of the inductive proximity switches will be made available on request.

