

Spring clamping cylinder pulling, with hydraulic return

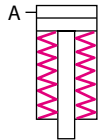

HILMA



Application:

- long-term clamping of moveable machine parts, dies, fixtures, pallets and workpieces

Function:

The force of the spring clamping cylinder is mechanically transmitted to the tie rod or the clamping spindle by a pre-loaded Belleville spring assembly. Hydraulic power is only required for unclamping the clamping cylinder.

Special features:

- ◆ large choice of clamping forces
- ◆ low-friction Belleville springs placed between hardened and ground thrust washers
- ◆ piston secured against rotation
- ◆ radial and axial oil ports
- ◆ rapid and easy installation

For power units,
please see product group 7

For accessories,
please see product group 11

Examples for application

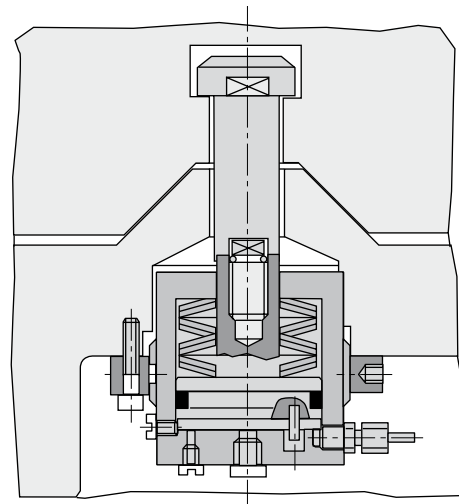
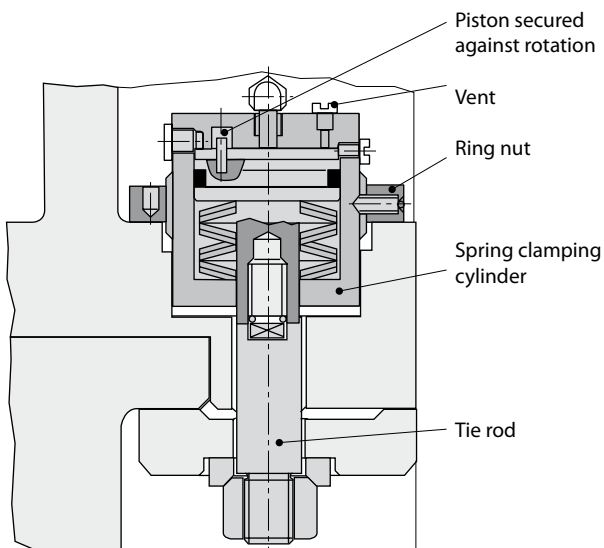

Subject to technical modification

Hilma-Römheld GmbH

Schützenstraße 74 · D-57271 Hilchenbach
Phone +49 (0) 2733 / 281-0 · Fax +49 (0) 2733 / 281-113 · www.hilma.de

2.1400

10/2008



Spring clamping cylinder pulling, with hydraulic return

Adjustment of clamping force, clamping and unclamping

1. Apply set pressure to spring clamping cylinder.
2. Adjust clamping position to be free from play by means of ring nut.
3. Secure ring nut against torsion. If necessary, secure cylinder against sliding. See examples for application.
4. For clamping, reduce set pressure.
5. For unclamping, apply unclamping pressure.
6. Check play of clamping point after approx. 1000 load changes at set pressure. If necessary, retighten ring nut and secure again.

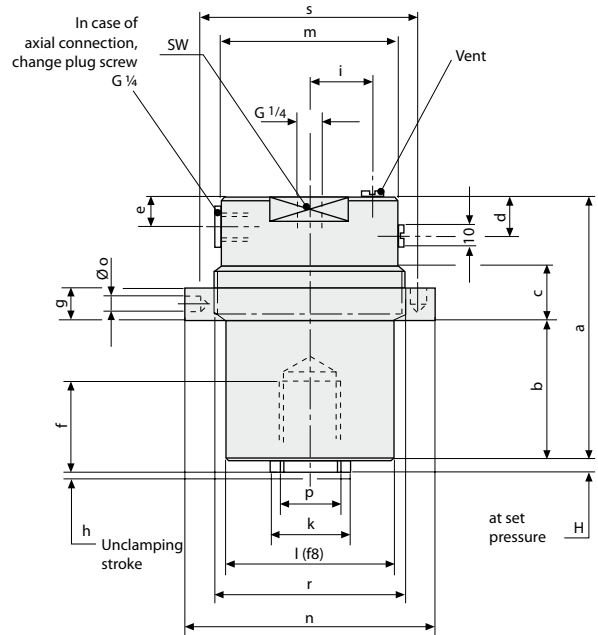

Please consult our technical sales staff

- if clamping forces have changed
- in case of an unclamping stroke > 1 mm
- in case of load cycles > 1 min.
- if aggressive fluids are used
- in case of temperatures below -15°C or above +60°C
- if the unclamping stroke must be limited
- if you require special versions

Clamping force (kN)	16	25	40	63	100	160	250	400
Set pressure (bar)	165	165	185	215	250	230	230	215
Uncl. pressure h = 0,5 mm (bar)	210	200	210	235	275	265	250	235
Uncl. pressure h = 1,0 mm (bar)	255	235	235	255	315	300	270	255
Oil consump. / 1mm stroke (cm ³)	1,3	2,0	2,9	3,9	5,0	9,5	14,3	25,4
a (mm)	95	105	120	132	147	170	230	280
b (mm)	45	50	60	70	80	75	100	130
c (mm)	20	20	25	25	30	45	55	65
d (mm)	22	22	22	23	23	33	62	65
e (mm)	11	11	11	12	12	28	57	62
f (mm)	24	30	36	45	45	50	60	65
g (mm)	13	14	14	16	16	18	20	50
i (mm)	18	20,5	27	32	36	34	38	50
k (mm)	20	25	30	40	40	50	70	90
l (f8) (mm)	55	65	75	85	95	142	170	220
m (mm)	55	65	75	89	99	137	163	212
n (mm)	85	95	110	125	140	180	220	270
o (mm)	6	8	8	8	8	10	10	15
p (mm)	M 14 x 1,5	M 18 x 1,5	M 22 x 1,5	M 30 x 1,5	M 30 x 1,5	M 38 x 1,5	M 45 x 1,5	M 58 x 2
r (mm)	M 58 x 1,5	M 68 x 1,5	M 78 x 1,5	M 92 x 1,5	M 102 x 1,5	M 140 x 2	M 168 x 3	M 218 x 4
H (mm)	4	4	4	6	6	6	6	6
SW (mm)	50	60	70	80	90	130	-	-
s (mm)	72	82	94	109	121	165	194	244
Weight (kg)	1,8	2,6	3,9	5,7	7,8	18,7	36,3	83
Part no.	1401 010	1402 010	1403 010	1404 010	1405 010	1406 010	1407 010	1408 010

Spring clamping cylinder, pulling, with hydraulic return



HILMA

Power-stroke-pressure diagrams

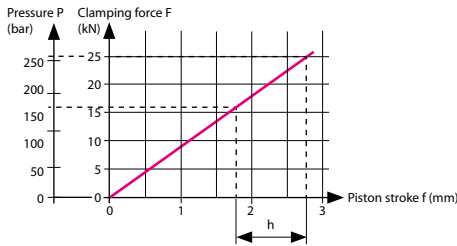

Clamping force (kN) at set pressure 165 bar	16
Unclamping pressure (bar) at unclamping stroke h 0,5 mm	210
Unclamping pressure (bar) at unclamping stroke h 1 mm	255
Operating pressure max. bar	270
Part no.	1401 010

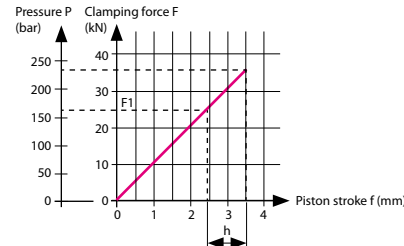

Clamping force (kN) at set pressure 165 bar	25
Unclamping pressure (bar) at unclamping stroke h 0,5 mm	200
Unclamping pressure (bar) at unclamping stroke h 1 mm	235
Operating pressure max. bar	250
Part no.	1402 010

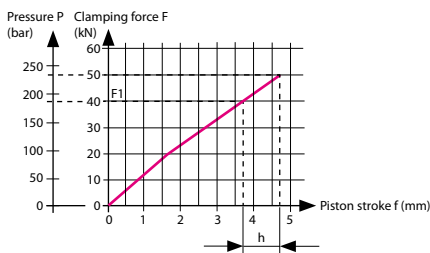

Clamping force (kN) at set pressure 185 bar	40
Unclamping pressure (bar) at unclamping stroke h 0,5 mm	210
Unclamping pressure (bar) at unclamping stroke h 1 mm	235
Operating pressure max. bar	250
Part no.	1403 010

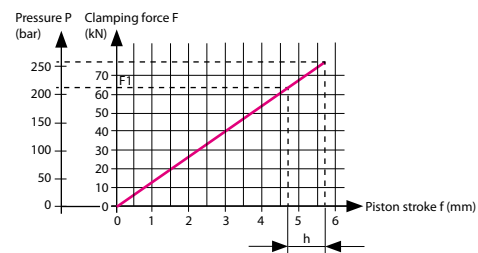

Clamping force (kN) at set pressure 215 bar	63
Unclamping pressure (bar) at unclamping stroke h 0,5 mm	235
Unclamping pressure (bar) at unclamping stroke h 1 mm	255
Operating pressure max. bar	270
Part no.	1404 010

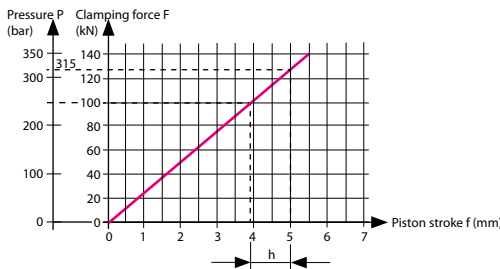

Clamping force (kN) at set pressure 250 bar	100
Unclamping pressure (bar) at unclamping stroke h 0,5 mm	275
Unclamping pressure (bar) at unclamping stroke h 1 mm	315
Operating pressure max. bar	320
Part no.	1405 010

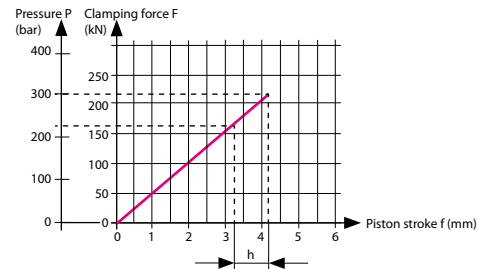

Clamping force (kN) at set pressure 230 bar	160
Unclamping pressure (bar) at unclamping stroke h 0,5 mm	265
Unclamping pressure (bar) at unclamping stroke h 1 mm	300
Operating pressure max. bar	320
Part no.	1406 010

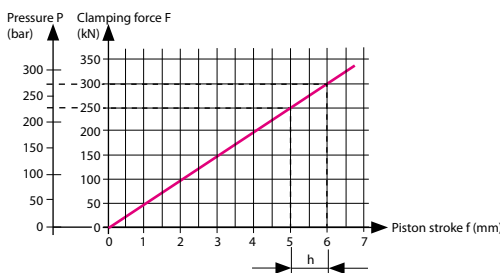

Clamping force (kN) at set pressure 230 bar	250
Unclamping pressure (bar) at unclamping stroke h 0,5 mm	250
Unclamping pressure (bar) at unclamping stroke h 1 mm	270
Operating pressure max. bar	285
Part no.	1407 010

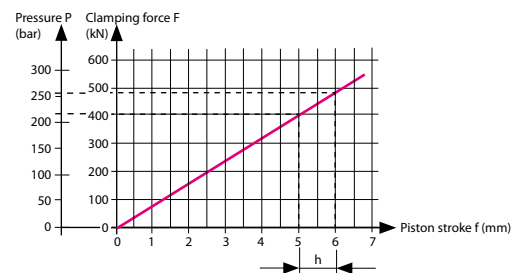

Clamping force (kN) at set pressure 215 bar	400
Unclamping pressure (bar) at unclamping stroke h 0,5 mm	235
Unclamping pressure (bar) at unclamping stroke h 1 mm	255
Operating pressure max. bar	270
Part no.	1408 010