



Applications:

- ▶ automatic clamping of dies on press rams
- ▶ for dies varying in width

Function:

A pusher chain driven with an electric motor moves the rapid clamping system with its attached clamping cylinder automatically to the clamping edge. The T-slot in the machine provides guidance for the chain and the clamping element. Clamping and unclamping of the cylinder is carried out by applying pressure to the cylinder, depending on the design. Following unclamping, the clamping element moves automatically from the clamping position into the parking position.

Special features:

- ▶ High functional safety by position monitoring and automatic travelling sequence
- ▶ Suitable for retrofit and installation in original equipment
- ▶ Tie rod made from high-strength forge steel
- ▶ No need for die standardisation (width and depth)
- ▶ Optimum utilisation of the ram area
- ▶ Clamping force of between 78 and 115 kN (other clamping forces on request)
- ▶ Central operation of all clamping elements
- ▶ Additional safety by mechanical self-locking clamp available on request

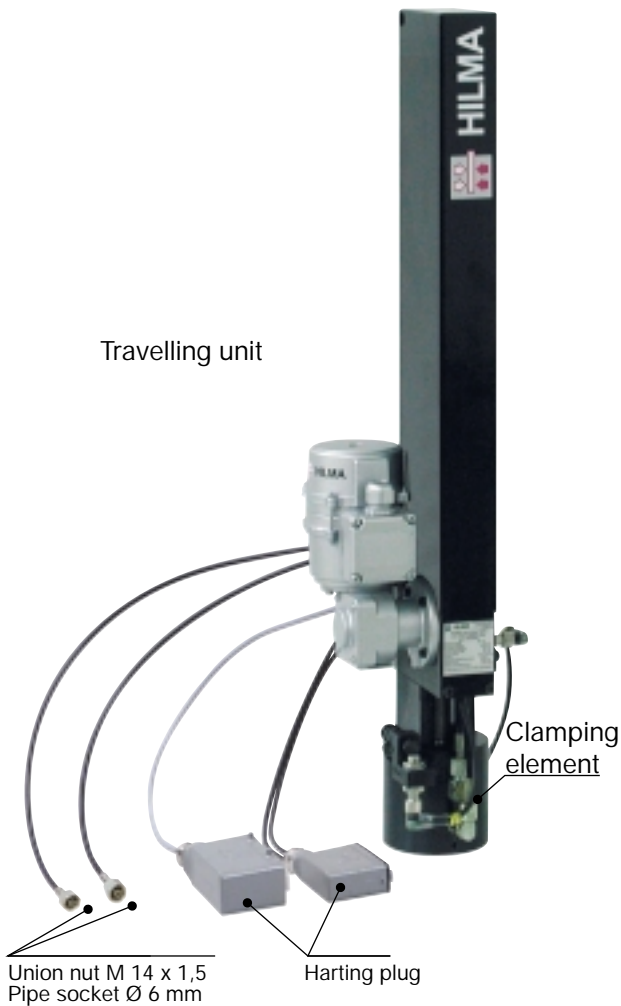

For power units
please see product group 7
For accessories
please see product group 11

Rapid clamping system with pusher chain fastened to the press ram of a double column press. A hollow piston cylinder serves as clamping element.



Rapid clamping system with pusher chain



HILMA

Design: Hollow piston cylinder, double-acting

Example of ordering: **8.2291.1 110**

Rapid clamping system with **hollow piston cylinder** as clamping element
T-slot: 28 mm
Travelling path: 500 mm

Functional dimension 'f' (in mm) to be quoted in the order

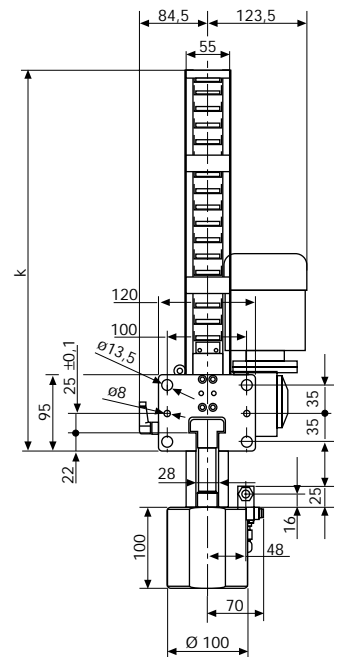
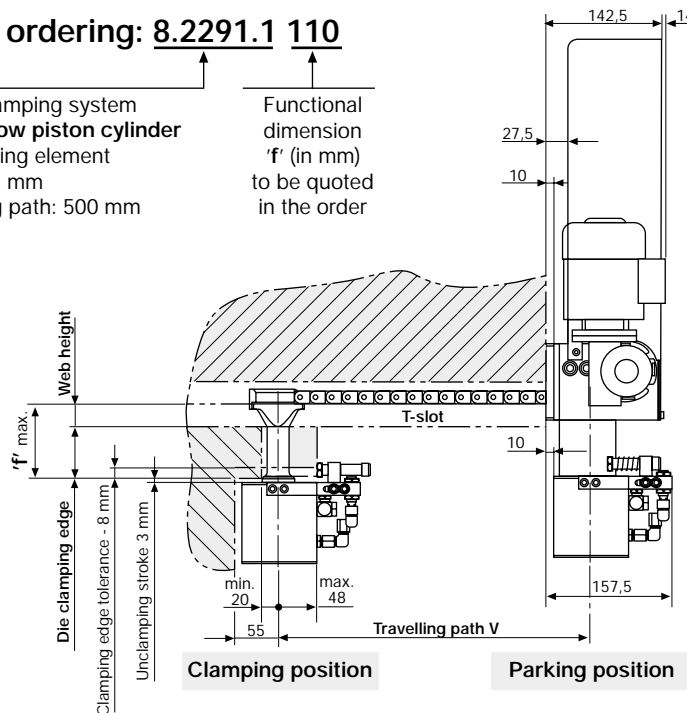

Part no.	T-slot to DIN 650 (mm)	Clamping force at 400 bar (kN)	Operating pressure (bar)	Oil consumption clamping/unclamping (cm ³ / mm)	Travelling path V (mm)	Dimension k (mm)	Clamping dimension 'f' tolerance (mm)
8.2291.1xxx	28	115	400	2,9 / 3,85	500	490	-8
8.2291.2xxx	28	115	400	2,9 / 3,85	1000	730	-8

Technical data:

- Travelling path V _____ see table *)
- Travelling speed _____ 150 mm/s
- Width of T-slot _____ see table DIN 650 *)
- Motor voltage _____ 400 V / 50 Hz / 3- *)
- Rated motor current _____ 0,18 A
- Motor output _____ 45 W
- Two proximity switches _____ 24 (10-30) V DC *)
 1. Parking position
 2. Die position
 3. A further proximity switch for "End of chain " is available on request
- Motor connection _____ Harting HAN3HvE *)
(plug with 500 mm cable length)
- Connections for proximity switches _____ Harting HAN10E *)
(plug with 500 mm cable length)
- Hydraulic connection _____ Union nut M 14 x 1,5 *)
(free hose length 500 mm)

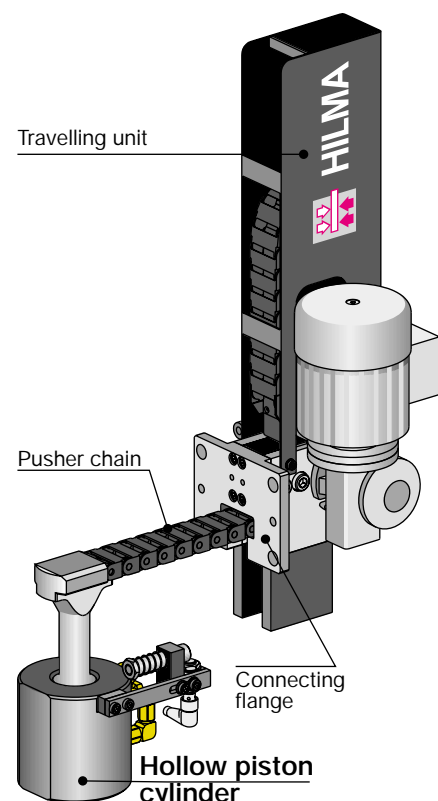

***) other versions as well as a spindle drive are available on request.**



Other details:
Pull-type clamping element with mechanical lock

Clamping element unclamped

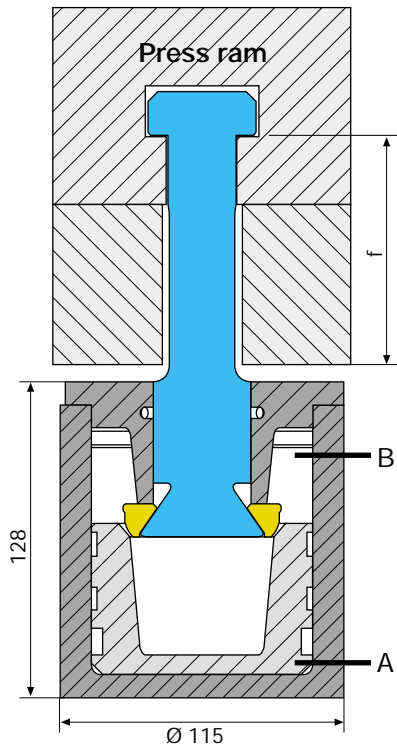

Clamping element clamped

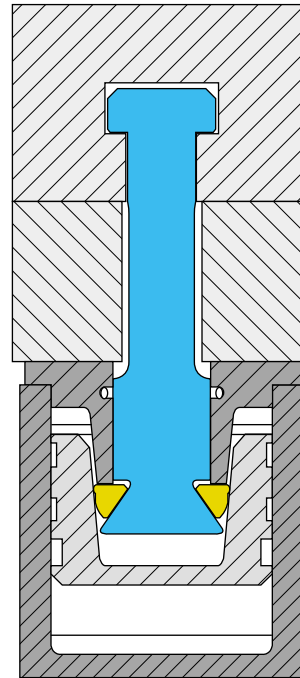

Application:

For clamping dies on the ram, the clamping force must be maintained by self-locking in the event of a hydraulic pressure drop.

Function:

The rapid clamping system moves the clamping element automatically into its clamping position. Pressure is applied to port A, the pull-type clamping element moves towards the clamping edge. Once the clamping element has come in contact with the die clamping surface, the maximum clamping power is applied, and the clamping element locks mechanically.

Mechanical self-lock ensures that the full clamping power will be maintained in the event of pressure drop.

For safety reasons, it is recommended that the hydraulic pressure is maintained.

For unclamping, relieve pressure at port A and apply pressure to port B. Following unclamping, the clamping element returns automatically into the parking position.

Technical data:

Clamping force:	100	kN
Max. operating pressure:	80	bar
Max. stroke:	8	mm
Positioning stroke:	3	mm
Max. clamping stroke:	4	mm



Design: Spring clamping cylinder, single-acting

Example of ordering: **8.2293.1 110**

Rapid clamping system with **spring clamping cylinder** as clamping element
T-slot: 28 mm
Travelling path: 500 mm

Functional dimension 'f' (in mm) to be quoted in the order

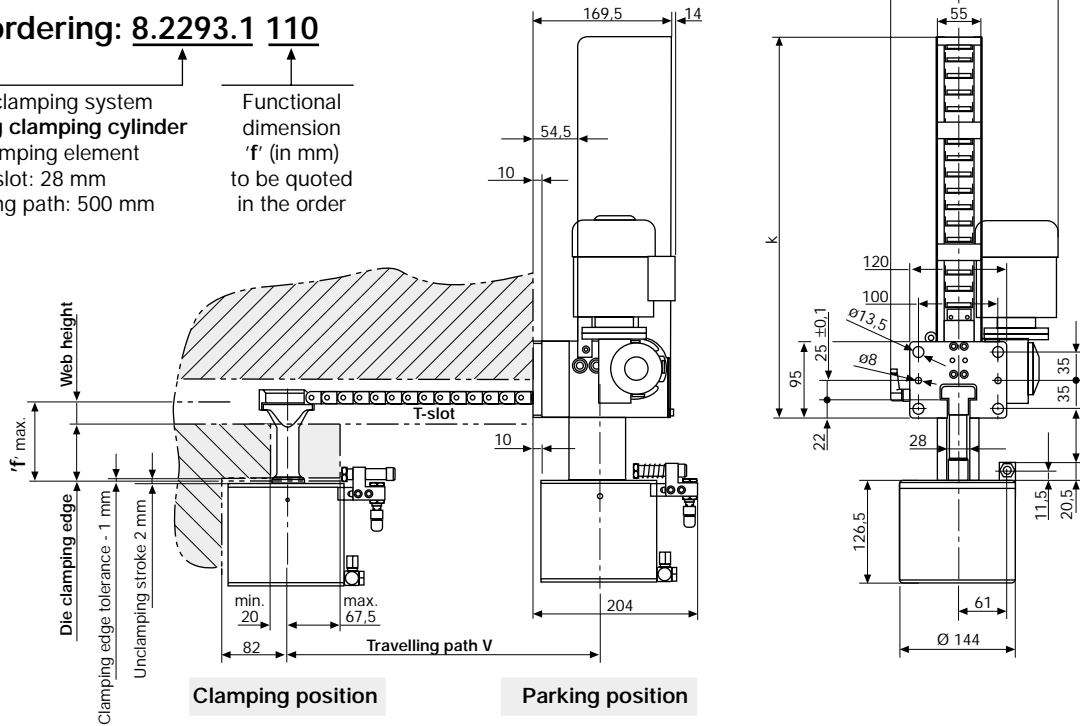

Part no.	T-slot to DIN 650 (mm)	Clamping force (kN)	Operating pressure unclamping (bar)	Oil consumption unclamping (cm ³ / mm)	Travelling path V (mm)	Dimension k (mm)	Clamping dimension 'f' tolerance (mm)
8.2293.1xxx	28	100	120	12,3	500	490	-1
8.2293.2xxx	28	100	120	12,3	1000	730	-1

Technical data:

- Travelling path V _____ see table *)
- Travelling speed _____ 150 mm/s
- Width of T-slot _____ see table DIN 650 *)
- Motor voltage _____ 400 V / 50 Hz / 3~ *)
- Rated motor current _____ 0,18 A
- Motor output _____ 45 W
- Two proximity switches _____ 24 (10-30) V DC *)
 1. Parking position
 2. Die position
 3. A further proximity switch for "End of chain " is available on request
- Motor connection _____ Harting HAN3HvE *)
(plug with 500 mm cable length)
- Connections for proximity switches _____ Harting HAN10E *)
(plug with 500 mm cable length)
- Hydraulic connection _____ Union nut M 14 x 1,5 *)
(free hose length 500 mm)

***) other versions as well as a spindle drive are available on request.**

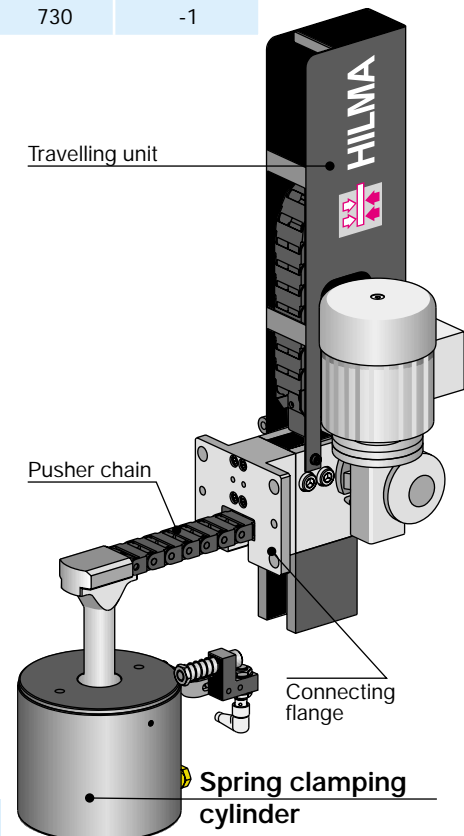

Rapid clamping system with pusher chain



HILMA

Design: Sliding clamp, single-acting

Example of ordering: **8.2294.1 110**

Rapid clamping system with **sliding clamp** as clamping element
T-slot: 28 mm
Travelling path: 500 mm

Functional dimension 'f' (in mm) to be quoted in the order

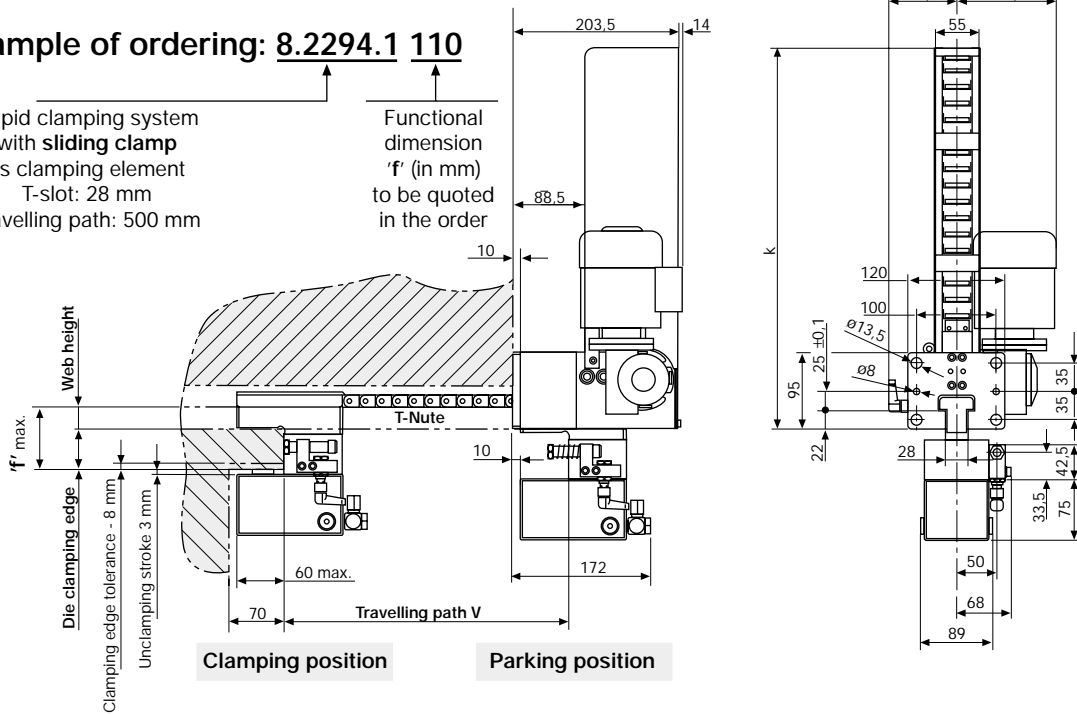

Part no.	T-slot to DIN 650 (mm)	Clamping force at 400 bar (kN)	Operating pressure (bar)	Oil consumption clamping (cm ³ / mm)	Travelling path V (mm)	Dimension k (mm)	Clamping dimension 'f' tolerance (mm)
8.2294.1xxx	28	78	400	1,5	500	490	-8
8.2294.2xxx	28	78	400	1,5	1000	730	-8

Technical data:

- Travelling path V _____ see table *)
- Travelling speed _____ 150 mm/s
- Width of T-slot _____ see table DIN 650 *)
- Motor voltage _____ 400 V / 50 Hz / 3- *)
- Rated motor current _____ 0,18 A
- Motor output _____ 45 W
- Two proximity switches _____ 24 (10-30) V DC *)
 1. Parking position
 2. Die position
 3. A further proximity switch for "End of chain " is available on request
- Motor connection _____ Harting HAN3HvE *)
(plug with 500 mm cable length)
- Connections for proximity switches _____ Harting HAN10E *)
(plug with 500 mm cable length)
- Hydraulic connection _____ Union nut M 14 x 1,5 *)
(free hose length 500 mm)

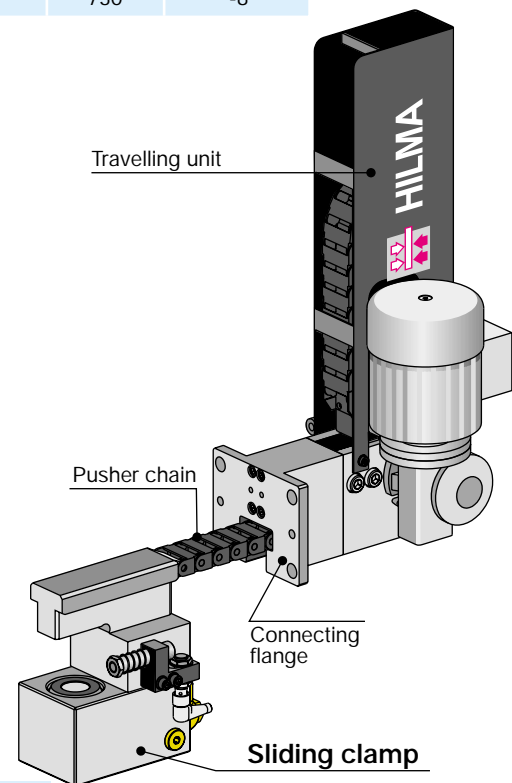

***) other versions as well as a spindle drive are available on request.**