



**Built-in piston**

4.1070



**Swing sink clamping element**

4.2150



**Swing clamping element**

4.2170



**Pull clamping element**

4.2180



**Pull clamping element with T-slot**

4.2350

4.2351



**Grip rail coupling**

4.2900

# Swing sink clamping element double-acting



# HILMA

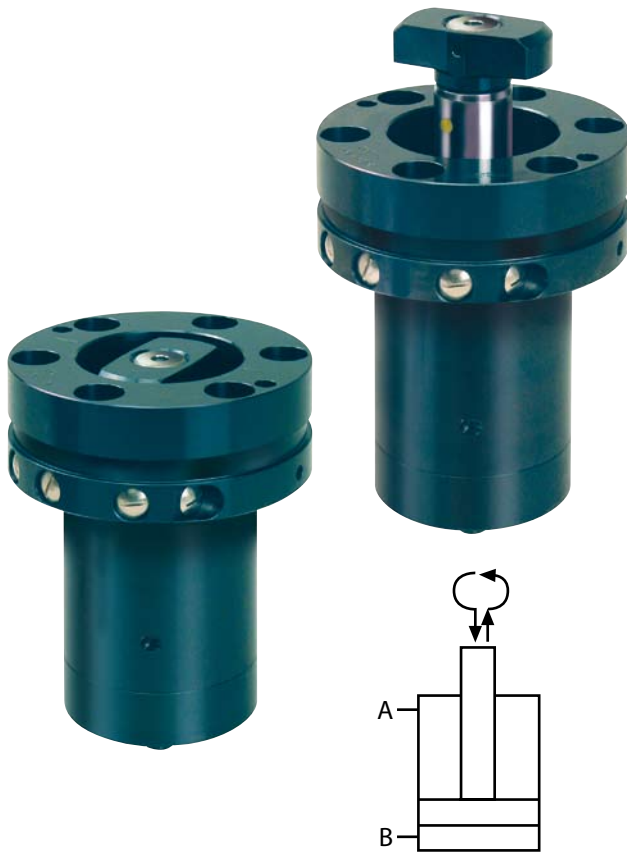

### Applications:

- integrated in press rams
- integrated in press beds
- in machine tools and equipment
- when the available space is limited
- when temperatures may reach 70° C

### Design:

Double-acting swing sink clamp with 90° swing angle. The piston is guided by a guide pin in such a manner that during part of the stroke a 45° rotation is carried out. Unclamping, change-over and clamping are monitored by inductive proximity switches.

The swing mechanism is protected by a spring-loaded overload protection and equipped with emergency hand operation. The tie rod, piston and swing mechanism are hardened.

### Special features:

- ◆ Ideal power transmission
- ◆ Compact design
- ◆ Clamping force of between 60 and 164 kN
- ◆ Position monitoring, emergency hand operation and overload protection combine to ensure high functional safety
- ◆ Compensates for large clamping edge tolerances ( $\pm 1.5$  mm)
- ◆ No colliding edges, smooth die positioning
- ◆ Optimum use of ram and bed surfaces
- ◆ Die clamping in barely accessible positions

For power units  
please see product group 7

For accessories  
please see product group 11

Swing sink clamps fastened  
in a double column press.  
The tie rod is extended (swing position).  
Easy die positioning is ensured  
by hydraulic roller blocs  
in T-slots and lateral stops





# Swing sink clamping element, double-acting



# HILMA

## Function:

The piston is guided by a guide pin in such a manner that during part of the stroke a 45° rotation is carried out just before reaching and just after leaving the piston upper rest position. The rotation is always anti-clockwise, no matter whether the piston extends or retracts.

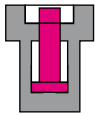

### 1. Unclamping position

The piston retracts completely. This permits an easy die change, as no parts project over the bed level. Proximity switch 2S1 monitors this position.

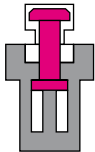

### 2. Change-over position for clamping

Valves Y1 and Y2 are energised, and pressure is applied to piston side B.

The tie rod passes through the slot of the clamping point and is then rotated by 45°. Proximity switch 2S2 monitors this position.

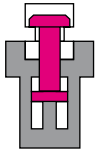

### 3. Clamping position

Valves Y1 and Y2 are de-energised, and pressure is applied to piston rod side A. The tie rod makes a further 45° rotation and is now transversely above the clamping point.

*The die is clamped.* Proximity switch 2S3 monitors this position.

Once the clamping pressure has been reached the power unit will be switched off by pressure switch 1S2.

In the event of a fall in pressure, the power unit is switched on by the pressure switch and builds up to the required clamping pressure.

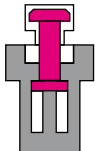

### 4. Change-over position for unclamping

Valves Y1 and Y2 are energised, and pressure is applied to piston side B. The tie rod is extended and then again rotated by 45°. Proximity switch 2S2 monitors this position.

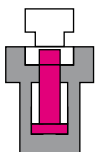

### 5. Clamping position

Valves Y1 and Y2 are de-energised, and pressure is applied to piston rod side A. The tie rod makes a further 45° rotation and passes through the slot of the clamping point as far as the end position.

Proximity switch 2S1 monitors this position.

*The die is unclamped.*

## Hydraulic schematics

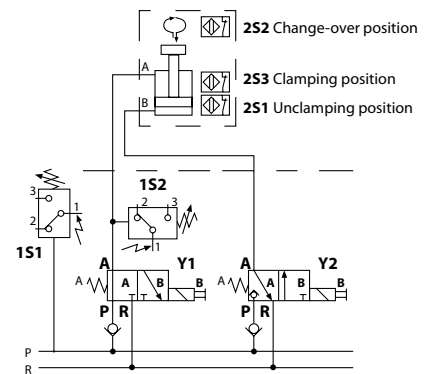

## Functional diagram

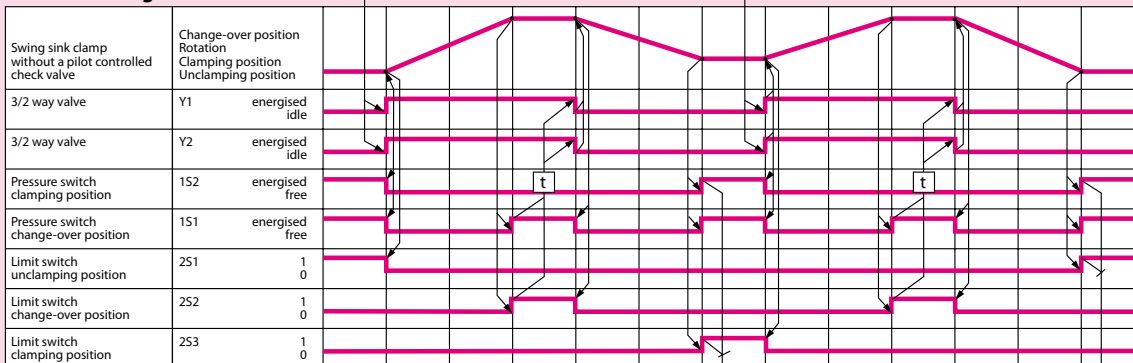



### Recommended installation

In order to ensure ease of servicing, two alternatives are offered for connecting the swing sink clamps.

#### Flanged connection

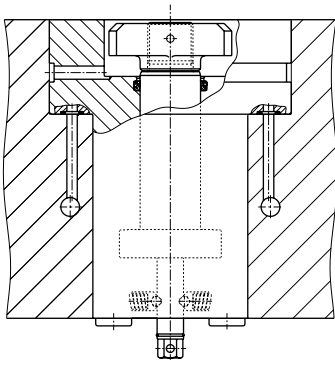

Hydraulic oil is fed through the drilled holes in the bed and in the ram. There are no exposed conduits or screw fittings. O-rings supplied with the clamping element provide for tight fitting. Easy installation, ease of servicing.

#### Pipe connection

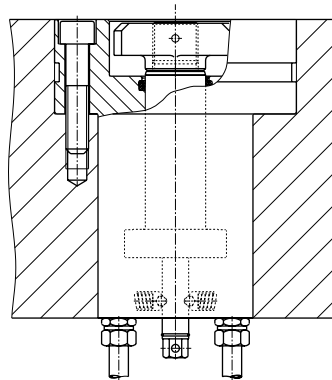

Pipes are recommended in applications where screw fittings are easily accessible and where pipes do not impede installation and dismantling of the swing sink clamps.

#### Drilled hole for flanged or pipe connection

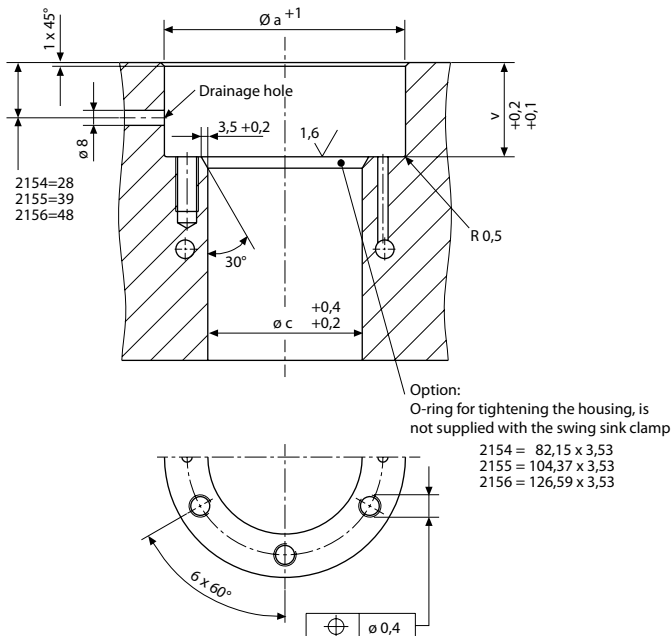

Flanged connection requires a plain and neat surface. The drainage hole may be drilled in any position provided that spray and separating agent can drain off freely.

#### Connection of the monitoring system for clamping and unclamping position

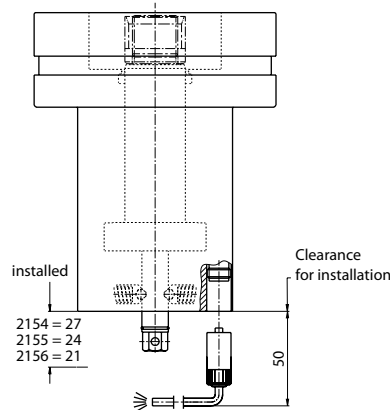

The three proximity switches are connected to the base of the swing sink clamp through a connecting lead with a screw coupling [IP 67]. The connecting lead is not supplied with the swing sink clamp and it has a separate part number, see page 6. Further installation may be carried out using a distribution block with an LED display.

# Swing sink clamping element, double-acting



# HILMA

## Accessories Flange

as a clamping point for installation in press dies

for clamping element Type	2154-160 2154-200	2155-160 2155-200	2156-160 2156-200
a (mm)	128	160	192
k (mm)	13	17	21
l (mm)	55	70	87
m (mm)	18	23	28
o (mm)	20	26	33
p (mm)	13	18	22
s (mm)	70	86	103
t (mm)	104	130	156
w (mm)	38	47	59
y (mm)	70	86	103
<b>Part no.</b>	<b>5700-016</b>	<b>5700-017</b>	<b>5700-018</b>

for clamping element Type	2154-160 2154-200	2155-160 2155-200	2156-160 2156-200
a (mm)	128	160	192
k (mm)	13	17	21
l (mm)	55	70	87
m (mm)	18	23	28
o (mm)	20	26	33
p (mm)	13	18	22
s (mm)	70	86	103
t (mm)	104	130	156
w (mm)	38	47	59
y (mm)	70	86	103
<b>Part no.</b>	<b>5700-019</b>	<b>5700-020</b>	<b>5700-021</b>

Flange

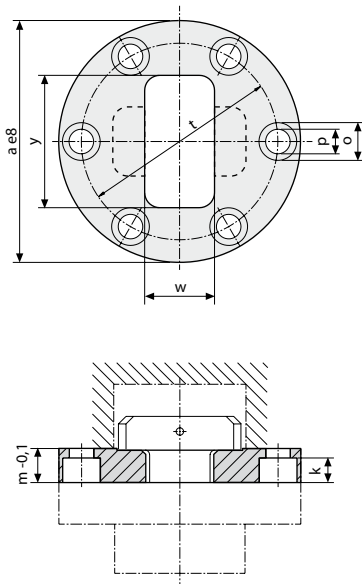

Flange

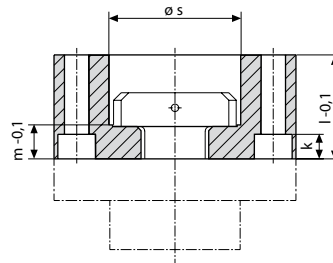

Location hole

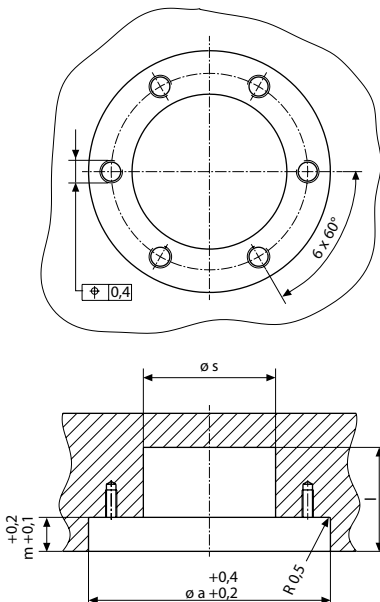

Location hole

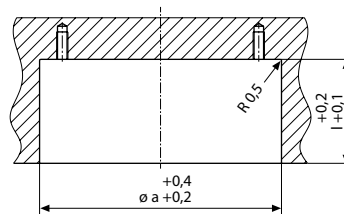

For more accessories, please see product group 11



### Electrical installation

#### Pin assignment for three-wire proximity switches

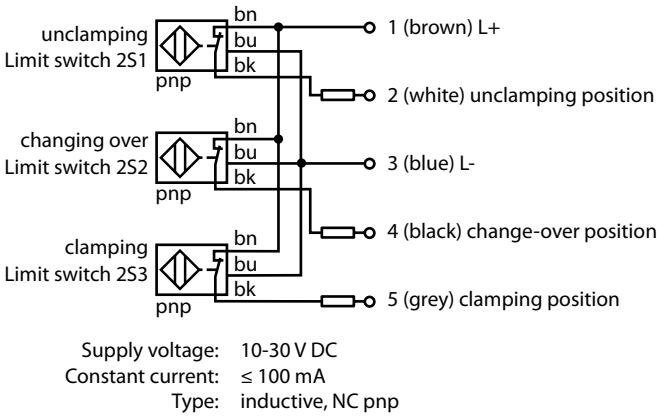

#### 5-pole connecting lead with screw coupling

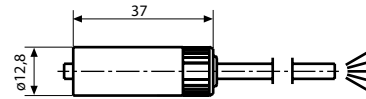

Cable length 5 m	<b>Part no.</b>	<b>5700-013</b>
Cable length 10 m	<b>Part no.</b>	<b>5700-014</b>

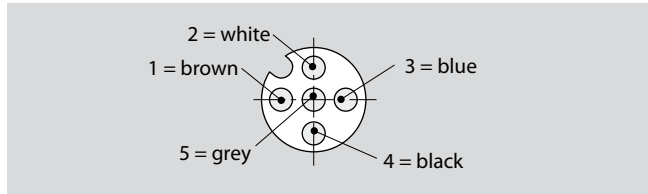

#### Distribution block with LED display for connecting 4 clamping elements

Easy installation!  
 LED display of the unclamping, change-over and clamping position of each clamping element.

Scope of delivery: 1 distribution block  
 4 coupler plugs, 5 poles  
 1 coupler plug, 16 poles

#### Wiring of output plug:

- Pin 1 = L+
- Pin 2 = L
- Pin 3 = 1L
- Pin 4 = 1U
- Pin 5 = 1S
- Pin 6 = 2L
- Pin 7 = 2U
- Pin 8 = 2S
- Pin 9 = 3L
- Pin 10 = 3U
- Pin 11 = 3S
- Pin 12 = 4L
- Pin 13 = 4U
- Pin 14 = 4S
- Pin 15 = free
- Pin 16 = free

**L = Unclamping position**  
**U = Change-over position**  
**S = Clamping position**

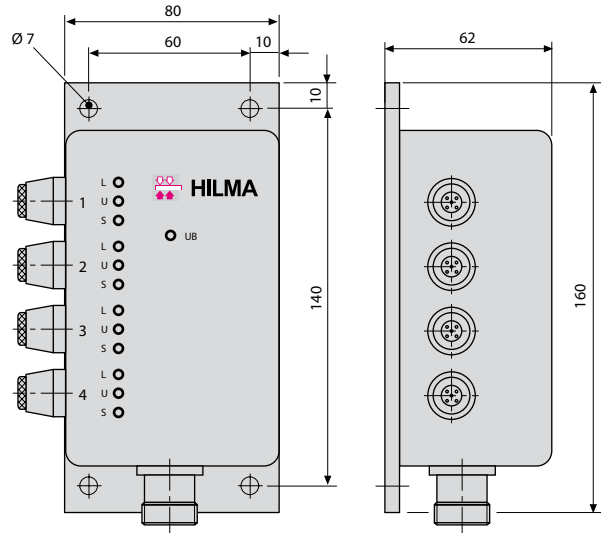

<b>Part no.</b>	<b>5700-015</b>
-----------------	-----------------

#### Hydraulic installation

Read the operating instructions before commissioning the system.

Adjust the displacement of the power unit so that clamping and unclamping cycles between 10 and 30 seconds are obtained. In order to prevent the swing mechanism from premature wear, the dynamic pressure at port B should not exceed 50 bar while the tie rods retract through the slot. Swing sink clamps which are grouped together should be connected to distribution blocks, in order to avoid series connection. Use pipes with larger diameter for connection to the power unit.

If in doubt, please send the installation plan to be reviewed.

Provide a pressure gauge connection in every hydraulic circuit for adjustment and to check operational data. Other parameters and recommendations for hydraulic installation of die clamping systems, are given in chapter no. 1 "General information".

#### Please note:

The full stroke of the piston must be realised, otherwise the swing mechanism may be damaged.