



Built-in piston

4.1070



Swing sink clamping element

4.2150



Swing clamping element

4.2170



Pull clamping element

4.2180



Pull clamping element with T-slot

4.2350

4.2351



Grip rail coupling

4.2900

Swing clamping element, double-acting



HILMA

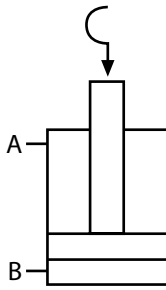

For power units
please see product group 7

For accessories
please see product group 11

Applications:

- integrated in press rams
- in machine tools and equipment
- when the available space is limited
- when temperatures may reach 70° C

Design:

Double-acting swing clamp with 90° swing angle. Unclamping and clamping are monitored by inductive proximity switches. The swing mechanism is protected by a spring-loaded, overload protection and is equipped with emergency hand operation. The tie rod, piston and swing mechanism are hardened. The hydraulic system is protected by a wiper ring.

Special features:

- ◆ Ideal power transmission
- ◆ Compact design
- ◆ Clamping force of between 60 and 164 kN
- ◆ Position monitoring, emergency hand operation and overload protection combine to ensure high functional safety
- ◆ Compensates for large clamping edge tolerances (± 1.5 mm)
- ◆ Optimum use of ram surface
- ◆ Die clamping in barely accessible positions



The swing clamps are fastened in the press ram.

The ram is in the upper position and the swing clamps are extended (die change position).

Subject to technical modification

Hilma-Römheld GmbH

Schützenstraße 74 · D-57271 Hilchenbach

Phone +49 (0) 2733 / 281-0 · Fax +49 (0) 2733 / 281-113 · www.hilma.de

4.2170

10/2008



Swing clamping element, double acting

Clamping force at 400 bar (kN)	60	104	164
Clamping force at 100 bar (kN)	15	26	41
Piston Ø e (mm)	54	70	88
Piston rod Ø d (mm)	32	40	50
Swing stroke i (mm)	13	18	24
Clamping stroke h (mm)	5	6	6
Oil consumption clamping (cm ³)	22	52	107
Oil consumption unclamping (cm ³)	34	77	158
Max. volume flow (cm ³ /s)	10	16	25
a (mm)	128	160	192
b (mm)	84	104	122
c (mm)	82	104	126
f (mm)	M 24 x 1,5	M 30 x 1,5	M 36 x 1,5
g	G ¼	G ⅜	G ⅜
k (mm)	13	17	21
l (mm)	55	70	87
m (mm)	18	23	28
n (mm)	51	68	85
o (mm)	20	26	33
p (mm)	13	18	22
q (mm)	34	42	52
r (mm)	65	80	95
s (mm)	70	86	103
t (mm)	104	130	156
u (mm)	30	38	45
v (mm)	20	28	35
w (mm)	38	47	59
x (mm)	5,5	8	8
y (mm)	70	86	103
z (mm)	4	5	6
Emergency hand operation SW (mm)	6	8	10
Weight (kg)	4,2	8,6	15
with pipe connection			
Part no.	2174-160	2175-160	2176-160
with flanged connection			
Part no.	2174-200	2175-200	2176-200

Max. operating pressure 400 bar
Other sizes and special versions are available on request.

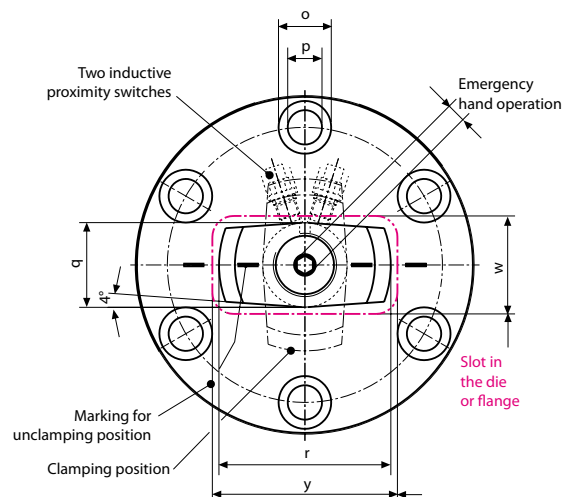
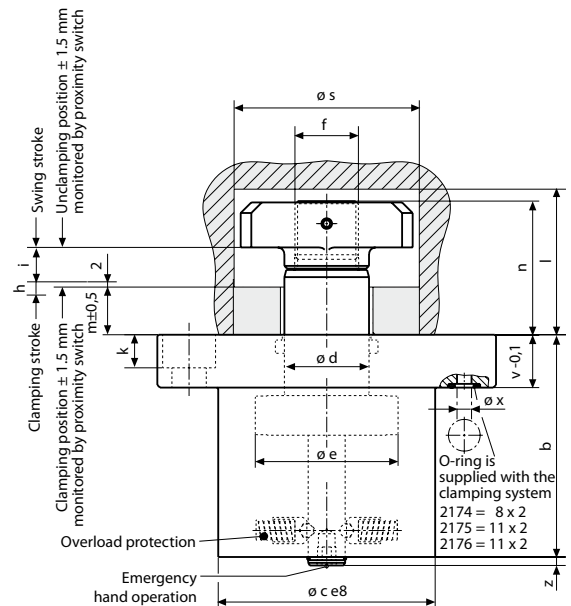
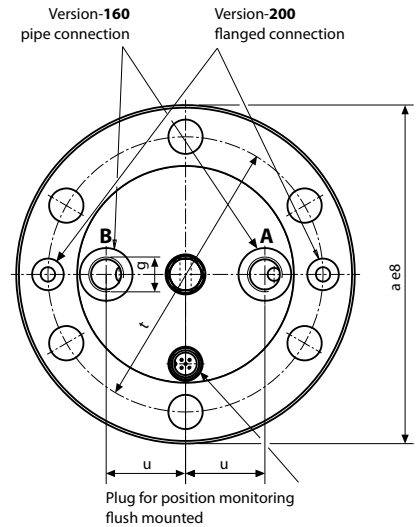

Please note!

Access to one of the two emergency hand controls is essential.

Swing clamping element double-acting



HILMA

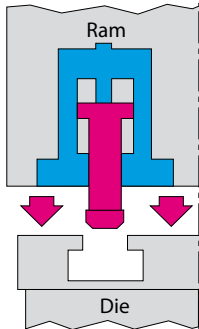

Function

Clamping

1. Push the die into the press with the swing clamping elements in the rest position.
2. Lower the press ram onto the upper part of the die. The tie rods of the swing clamping elements will pass through the clamping slots of the upper die.
3. The swing clamping elements are operated by means of a power unit. The tie rod rotates by 90° and is then in a transverse position to the clamping point. The upper die is hydraulically clamped. Once the clamping pressure has been reached the power unit will be switched off through pressure switch 1S2. In the event of a fall in pressure, the power unit is switched on by means of the pressure switch and builds up to the required clamping pressure.

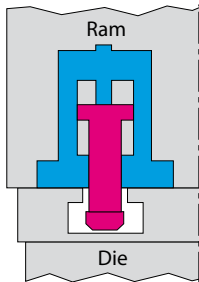

Unclamping

1. Move the dies together and return the swing clamping elements into the unclamping position by means of energising valves Y1 and Y2. The tie rod rotates by 90° and can then pass through the clamping slots of the upper die.
2. Move the press ram upwards and take the die out.

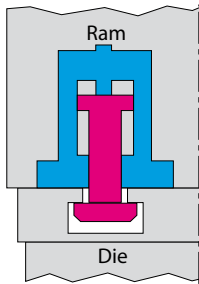

The clamping and unclamping positions are monitored by inductive proximity switches.

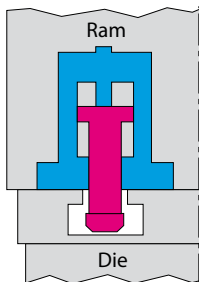

Functional diagram

Swing clamping elements	unclamping position clamping position	Unclamping position 0 - degrees	Swing stroke	Linear stroke	clamping position 90 - degrees	Linear stroke	Swing stroke	Unclamping position 0 - degrees
3/2 way valve	Y1	energised idle						
3/2 way valve	Y2	energised idle						
Pressure switch clamping position	1S2	energised free						
Pressure switch unclamping position	1S1	energised free						
Limit switch, unclamping position	2S1	1 0						
Limit switch, clamping position	2S2	1 0						

Hydraulic schematics

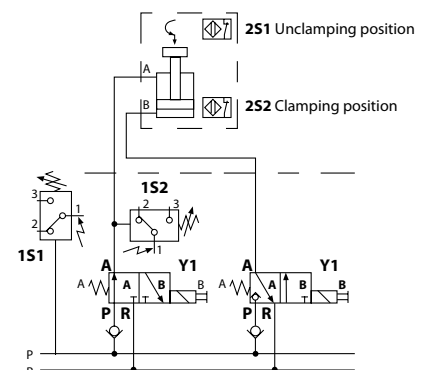



Recommended installation

In order to ensure ease of servicing, two alternatives are offered for connecting the swing clamps.

Flanged connection

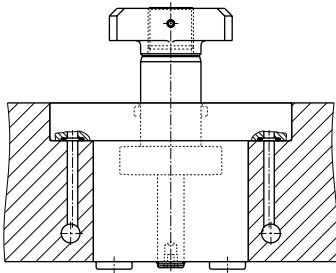

Hydraulic oil is fed through the drilled holes in the bed and in the ram. There are no exposed conduits or screw fittings.

O-rings supplied with the clamping element provide for tight fitting. Easy installation, ease of servicing.

Pipe connection

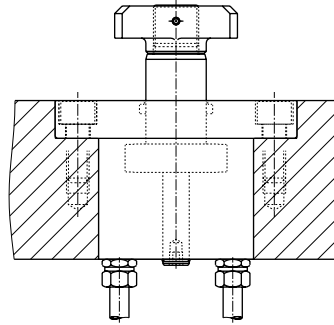

Pipes are recommended in applications where screw fittings are easily accessible and where pipes do not impede installation and dismantling of the swing clamps.

Drilled hole for flange or pipe connection

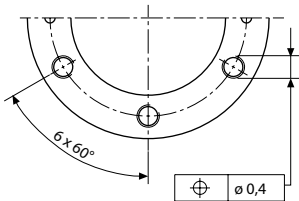
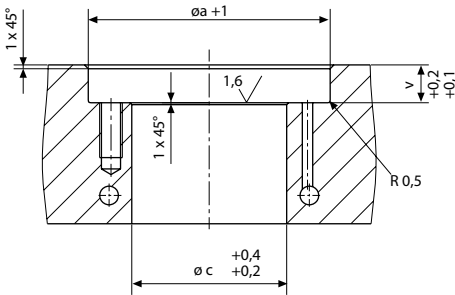

Flanged connection requires a plain and neat surface.

Connection of the monitoring system for clamping and unclamping position

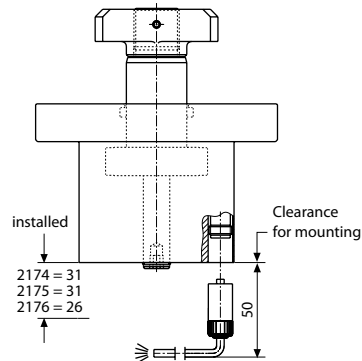

Both proximity switches are connected to the base of the swing clamp through a connecting lead with a screw coupling [IP 67]. The connecting lead must be ordered separately. Further installation may be carried out using a distribution block with an LED display, see page 6.

Swing clamping element double-acting



HILMA

Accessories Flange

as a clamping point for installation in press dies

for clamping element Type	2174-160 2174-200	2175-160 2175-200	2176-160 2176-200
a (mm)	128	160	192
k (mm)	13	17	21
l (mm)	55	70	87
m (mm)	18	23	28
o (mm)	20	26	33
p (mm)	13	18	22
s (mm)	70	86	103
t (mm)	104	130	156
w (mm)	38	47	59
y (mm)	70	86	103
Part no.	5700-016	5700-017	5700-018

for clamping element Type	2174-160 2174-200	2175-160 2175-200	2176-160 2176-200
a (mm)	128	160	192
k (mm)	13	17	21
l (mm)	55	70	87
m (mm)	18	23	28
o (mm)	20	26	33
p (mm)	13	18	22
s (mm)	70	86	103
t (mm)	104	130	156
w (mm)	38	47	59
y (mm)	70	86	103
Part no.	5700-019	5700-020	5700-021

Flange

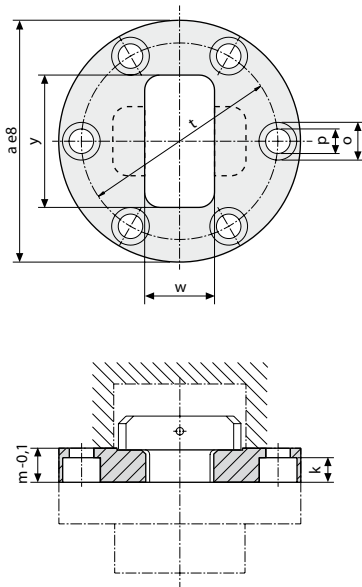

Flange

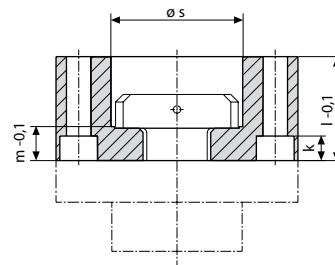

Location hole

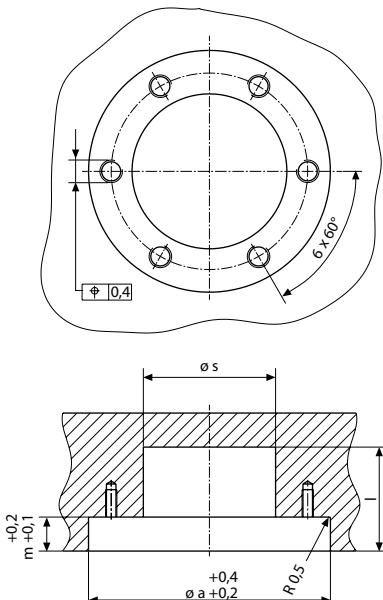

Location hole

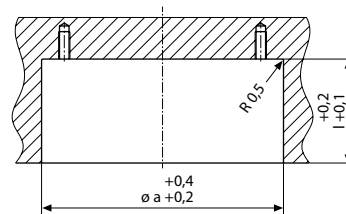

For more accessories, please see product group 11



Electrical installation

Pin assignment for three-wire proximity switches

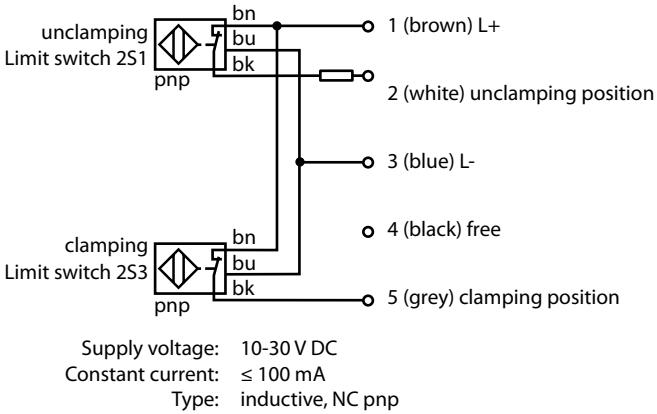

5-pole connecting lead with screw coupling

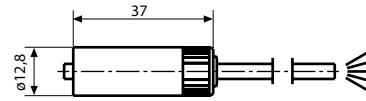

Cable length 5 m	Part no.	5700-013
Cable length 10 m	Part no.	5700-014

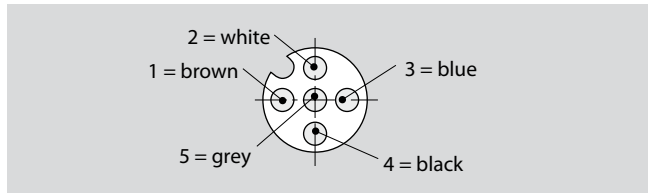

Distribution block with LED display for connecting 4 clamping elements

Easy installation!
 LED display of the unclamping, change-over and clamping position of each clamping element.

Scope of delivery: 1 distribution block
 4 coupler plugs, 5 poles
 1 coupler plug, 16 poles

Wiring of output plug:

- Pin 1 = L+
- Pin 2 = L
- Pin 3 = 1L
- Pin 4 = do not use
- Pin 5 = 1S
- Pin 6 = 2L
- Pin 7 = do not use
- Pin 8 = 2S
- Pin 9 = 3L
- Pin 10 = do not use
- Pin 11 = 3S
- Pin 12 = 4L
- Pin 13 = 4do not use
- Pin 14 = 4S
- Pin 15 = free
- Pin 16 = free

L = Unclamping position
U = not assigned
S = Clamping position

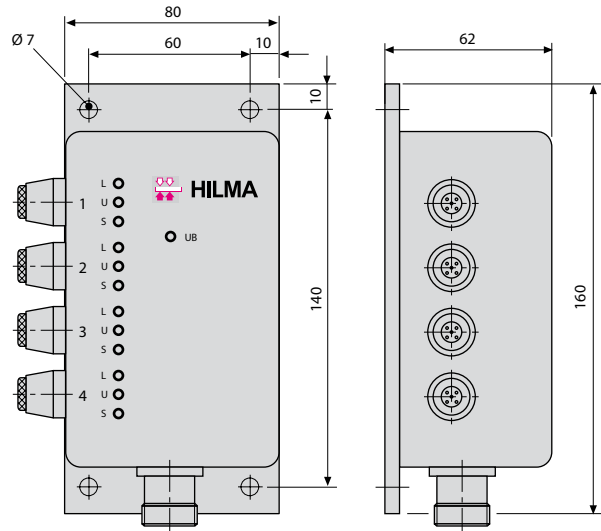

Part no.	5700-015
-----------------	-----------------

Hydraulic installation

Read the operating instructions before commissioning the system.

Adjust the displacement of the power unit so that clamping and unclamping cycles between 10 and 30 seconds are obtained. In order to prevent the swing mechanism from premature wear, the dynamic pressure at port B should not exceed 50 bar while the tie rods retract through the slot. Swing sink clamps which are grouped together should be connected to distribution blocks, in order to avoid series connection. Use pipes with larger diameter for connection to the power unit.

If in doubt, please send the installation plan to be reviewed.

Provide a pressure gauge connection in every hydraulic circuit for adjustment and to check operational data. Other parameters and recommendations for hydraulic installation of die clamping systems, are given in chapter no. 1 "General information".