

Pull clamping element with T-slot double-acting

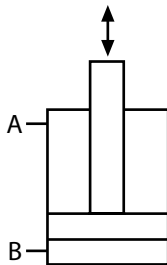

HILMA



Applications:

- installation in press rams
- installation in press beds
- integrated in a spacer plate
- when the available space is limited

Function:

The pull clamping element with a T-slot facilitates the standardisation of dies using T-slot bars or Tnuts which are fastened to the die. The hydraulic oil is fed either through the drilled holes in the bed and the ram or through pipes. The tie rod and the piston are hardened and ground, and the hydraulic system is protected against dirt by wiper rings.

Special features:

- ◆ Compact design
- ◆ The bed and ram can also be used for manual clamping
- ◆ Ideal power transmission with centrally arranged clamping elements
- ◆ Optimum use of bed and ram surfaces

For power units
please see product group 7

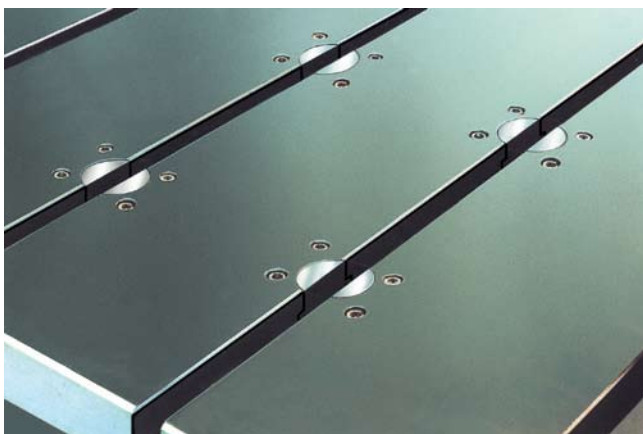

Pull clamping elements with T-slot installed in a press bed

Example of application:

Die clamping in a press

Ram: Clamping of the upper die using double T-slot bars

Bed: Clamping of the lower die using firmly mounted T-slot bars

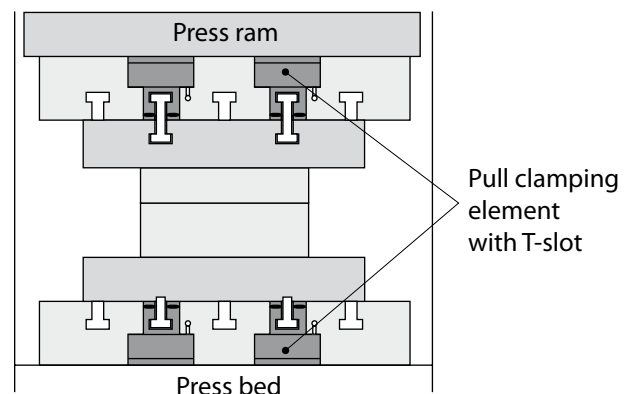

Subject to technical modification

Hilma-Römheld GmbH

Schützenstraße 74 · D-57271 Hilchenbach
Phone +49 (0) 2733 / 281-0 · Fax +49 (0) 2733 / 281-113 · www.hilma.de

4.2350

10/2008



For T-slot to DIN 650	18	22	28
Clamping force at 400 bar (kN)	55,2	76	144
Clamping force at 100 bar (kN)	13,8	19	36
Piston \varnothing l (mm)	70	80	105
Piston rod \varnothing d H7/f7 (mm)	56	63	80
Stroke (mm)	6	6	6
Oil consumption clamping (cm ³)	9	12	22
Oil consumption unclamping (cm ³)	23	30	52
a (mm)	18	22	28
b (mm)	30	37	46
c (mm)	100	115	150
e (mm)	24	28	32
f (mm)	14	18	22
g (mm)	M8	M10	M12
h (mm)	72	78	78
k (mm)	111	125	135
n (mm)	15,5	19,5	25,5
$o \pm 0,05$ (mm)	42	47,5	62,5
p (mm)	29,7	33,6	44,2
s (mm)	50	56	70
Weight (kg)	4,1	5,8	10
Part no.	2354-050	2355-050	2356-050

Max. operating pressure 400 bar
Other sizes and special versions are available on request.

Pull clamping element

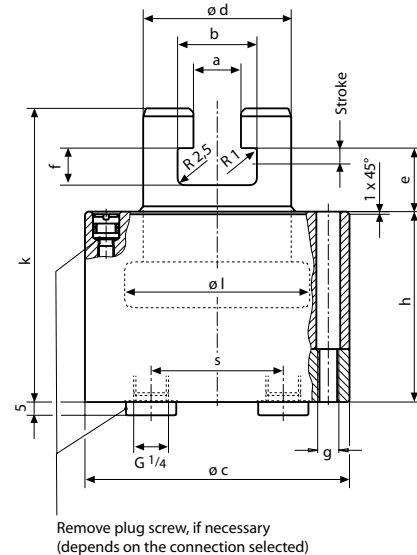

Remove plug screw, if necessary (depends on the connection selected)

Accessories (for ordering with the clamping element)

Plug-in connector for flanged connection

Part no. 9210-132

Plug-in connector

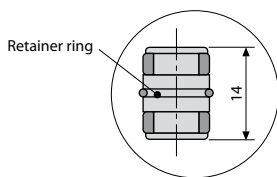

Accommodation space

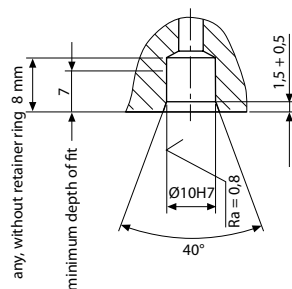

Type of drilled connection hole for plug-in connector

Drilled location hole

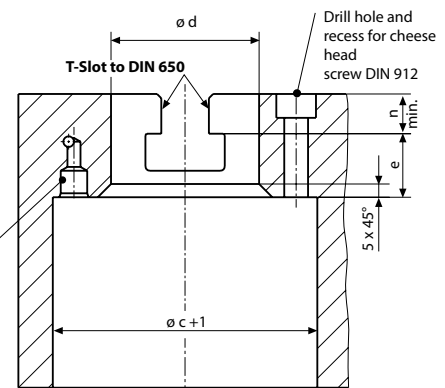

Important information

Make sure that the T-slot of the clamping piston is subject to an axial load only. The T-nut must be in contact over its complete surface. Transverse loads must be avoided. In view of the surface ratio of the pull clamping elements, only check valves having a minimum ratio of 3.5 : 1 may be used for maintaining the clamping force.

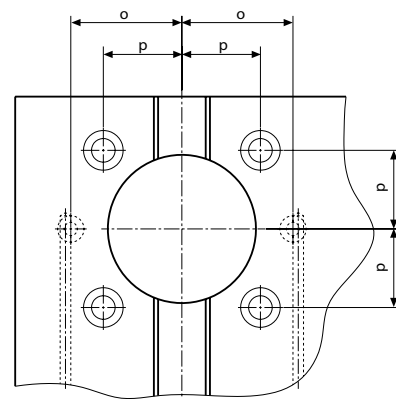

Pull clamping element with T-slot double-acting



HILMA

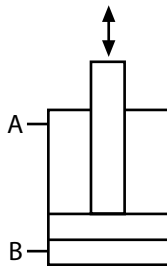

For power units
please see product group 7

Applications:

- installation in press rams
- installation in press bed
- integrated in spacer plate
- when the available space is limited

Function:

The pull clamping element with a T-slot facilitates significantly the standardisation of dies using T-slot bars or T-nuts which are fastened to the die.

The hydraulic oil is fed either through the drilled holes in the bed and the ram or through pipes.

The tie rod and the piston are hardened and ground, and the hydraulic system is protected against dirt by wiper rings.

Special features:

- ◆ Installation directly in the bed or in the ram
- ◆ Compact design
- ◆ Dies are easily adaptable
- ◆ The bed and ram can also be used for manual clamping
- ◆ Ideal power transmission with centrally arranged clamping elements
- ◆ Optimum use of bed and ram surfaces

Example of application:

Die clamping in a press

Ram: Clamping of the upper die using double T-slot bars

Bed: Clamping of the lower die using firmly mounted T-slot bars

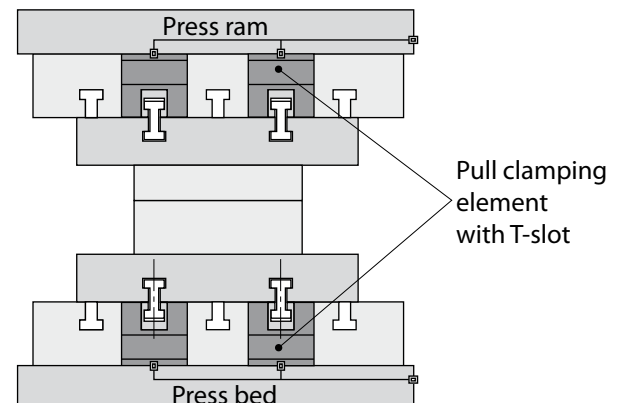



Pull clamping element with T-slot double-acting

For T-slot to DIN 650	18	22	28
Clamping force at 400 bar (kN)	55,2	76	144
Clamping force at 100 bar (kN)	13,8	19	36
Piston Ø l (mm)	70	80	105
Piston rod Ø d H7/f7 (mm)	56	63	80
Stroke (mm)	6	6	6
Oil consumption clamping (cm ³)	9	12	22
Oil consumption unclamping (cm ³)	23	30	52
a (mm)	18	22	28
b (mm)	30	37	46
c e 8 (mm)	110	130	166
e (mm)	96	106	110
f (mm)	14	18	22
g (mm)	M12	M16	M20
h (mm)	21	23	27
k (mm)	111	125	135
n (mm)	15,5	19,5	25,5
o (mm)	31,1	36,2	46,7
p ± 0,05 (mm)	15	15	15
Weight (kg)	6,1	9,5	16,6
Connection lengthways to the T-slot			
Part no.	2354-060	2355-060	2356-060
Connection crosswise to the T-slot			
Part no.	2354-065	2355-065	2356-065

Max. operating pressure 400 bar
Other sizes and special versions are available on request.

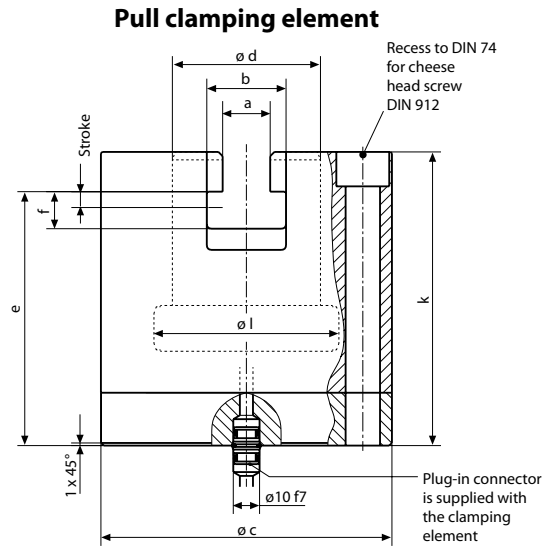

Drilled location hole

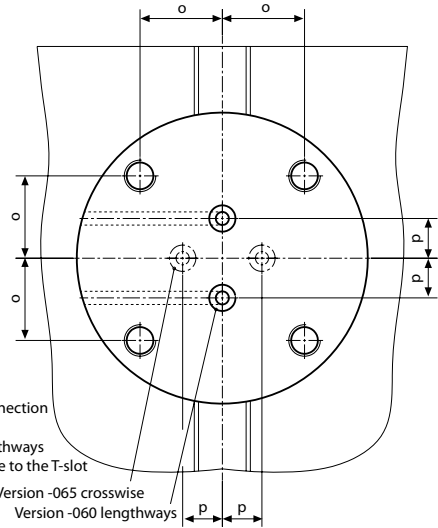
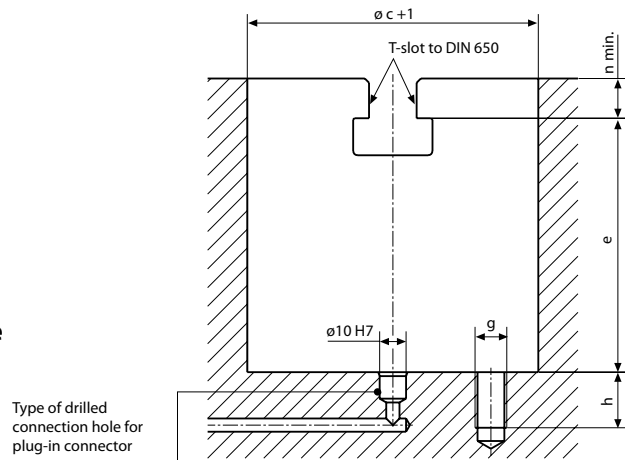

Plug-in connector for flanged connection Part no. 9210-132 (is supplied with the clamping element)

Plug-in connector

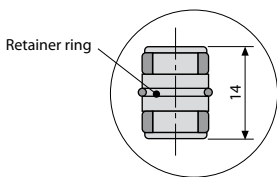

Accommodation space

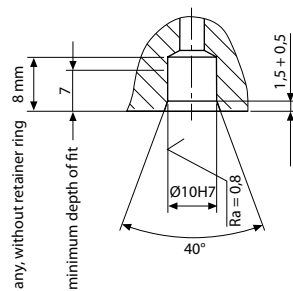

Important information

Make sure that the T-slot of the clamping piston is subject to an axial load only. The T-nut must be in contact over its complete surface. Transverse loads must be avoided. In view of the surface ratio of the pull clamping elements, only check valves having a minimum ratio of 3.5 : 1 may be used for maintaining the clamping force.