

Clamping block, mechanical with integral high-pressure spindle



HILMA



Applications:

- for clamping and locking dies on press beds and rams
- on beds of machine tools
- when the available space is limited

Function:

The high-pressure spindle is manually screwed against the die clamping edge. The clamping force is built up by turning the hexagon nut (SW 1) in a clockwise direction using a torque wrench.

The clamping force achieved depends on the tightening torque selected with the torque wrench.

Special features:

- ◇ Suitable for retrofit
- ◇ Compact design
- ◇ Clamping force of between 40 and 80 kN
- ◇ High clamping force with low torque
- ◇ Compensates for large clamping edge tolerances
- ◇ Self-locking by patented wedge system
- ◇ Individually usable

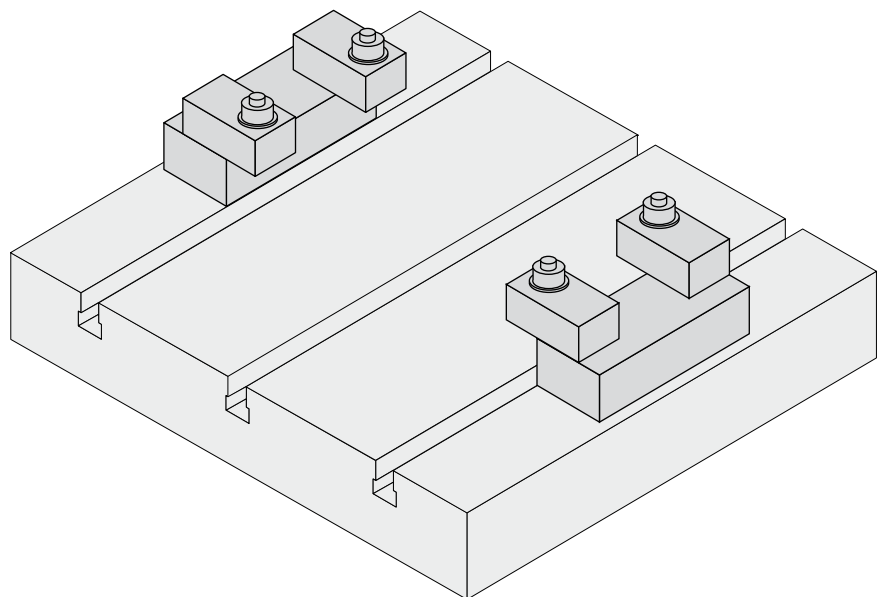

Clamping block with high-pressure spindle,
mounted on spacer ledges



HILMA



Clamping block, mechanical with integral high-pressure spindle

Clamping force (kN)	40	80
Clamping stroke (mm)	1,5	2,2
Max. tightening torque (Nm)	45	90
a (mm)	104	126
b (mm)	65	80
c (mm)	36	43
d (mm)	19	28
e (mm)	83	99
f (mm)	50	57
g (mm)	M 36 x 3	M 48 x 3
h (mm)	40	50
k (mm)	3	3
l (mm)	91	111
m (mm)	24	29
n (mm)	M 16	M 20
o (mm)	24	30
Max. travelling path s (mm)	30	35
SW 1 (mm)	13	17
SW 2 (mm)	30	41
Weight (kg)	2,3	4,0
Part no.	2212-111	2213-111

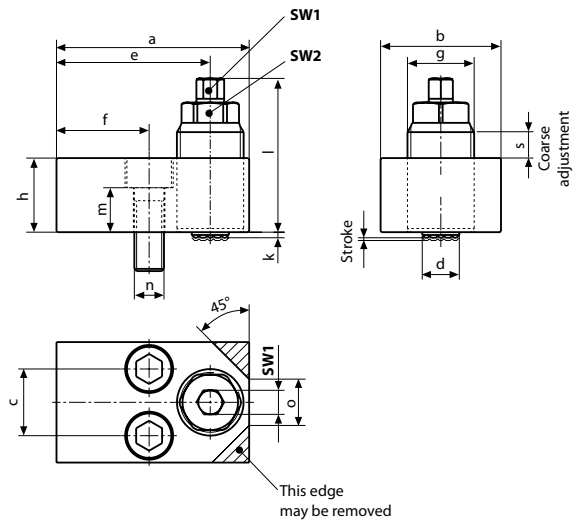

Accessory:

Torque wrench 20 - 100 Nm
Part no. 9.3792.6610

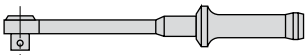

Note:

Before applying the tightening torque, the high-pressure spindle must be screwed against the clamping edge so that there is no play.

If the parts are not rigid, tighten the high-pressure spindle using the hexagon nut (SW 2) until there is no play.