

# Roller and ball bars for easy and safe die change



# HILMA

## T-slot tolerances acc. to DIN 650

a	b	c	h min.	h max.	n max.
18 H8	30 <sup>+2</sup>	12 <sup>+2</sup>	30	36	1,6
22 H8	37 <sup>+3</sup>	16 <sup>+2</sup>	38	45	1,6
28 H8	46 <sup>+4</sup>	20 <sup>+2</sup>	48	56	1,6
36 H8	56 <sup>+4</sup>	25 <sup>+3</sup>	61	71	2,5

Dimensions in mm

$h_{min.}$  = smallest dimension acc. to DIN 650

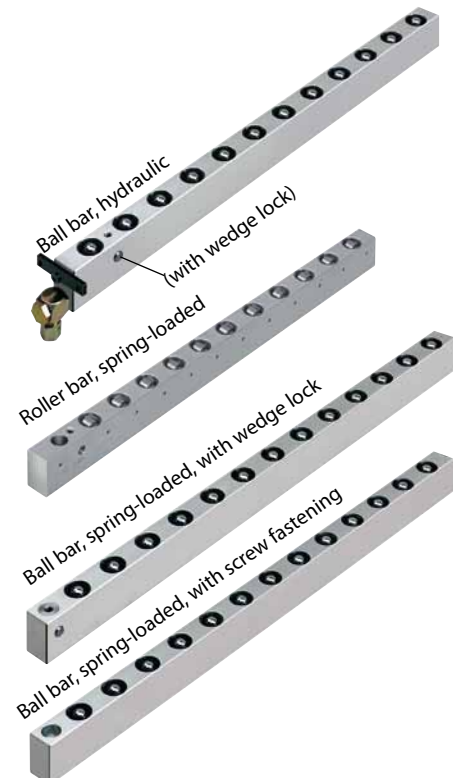
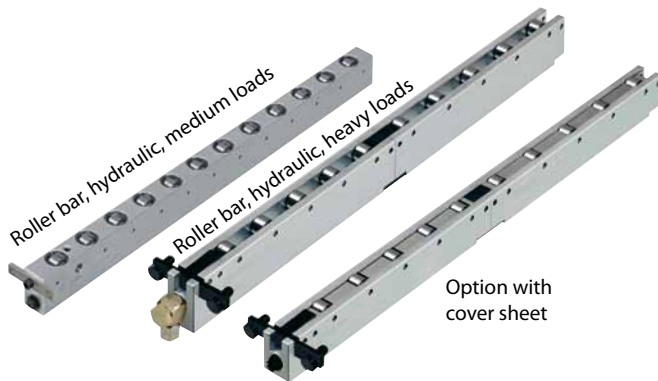
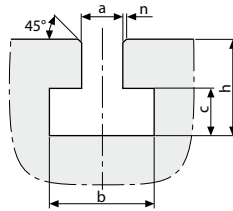

Load: 20 - 100 kg  
Hole: 20 - 40 mm



Load: 40 - 220 kg  
Hole: 20 - 40 mm

## Applications:

- in T-slots and rectangular slots of press beds for easy die change
- die change rationalisation

## Roller bar, hydraulically lifted

for heavy loads, for linear movement of dies:

On the underside of the roller bar lifting pistons are provided. Pressure is applied to these pistons using hydraulic pressure generators, which lift then the complete roller bar. The die positioned on the roller bars is not in contact with the table top and can be easily moved and positioned. The basic bodies are made from a high-strength and robust aluminium alloy.

Max. operating pressure: 400 bar

Load-bearing capacity: up to 160 kN/m, roller spacing 50 mm.

Any length up to 2500 mm is possible using modular segments

Fastening of the roller bar using a fastening plate.

## Roller bar, hydraulically lifted

for medium loads, for linear movement of dies:

Other than in the case of the above roller bar version, lifting pistons are provided below each roller allowing each roller to be lifted individually.

The basic body of the bar remains in its position. They are made from a high-strength aluminium alloy

Max. operating pressure: 120 bar.

Load-bearing capacity: up to 99 kN/m, flexible roller spacing and orientation.

Any length in a single piece design up to 2900 mm.

Fastening of the roller bar using a fastening plate or a wedge lock.

## Ball bar, hydraulically lifted for medium loads, for flexible horizontal movement of dies:

Oil pressure is applied using a hydraulic pressure generator to lift each ball bar individually. The die positioned on the ball bars is not in contact with the table top and can be easily moved.

Max. operating pressure: 100 bar

Load-bearing capacity: up to 55 kN/m, flexible ball spacing.

Any length in a single piece design up to 2900 mm.

Fastening of the ball bar using a fastening plate or a wedge lock.

## Ball bar with spring pack for lightweight loads for flexible horizontal movement of dies:

When preloaded, the balls project over the table level by up to 2 mm.

If the die is clamped, the balls are pressed into the bar body against the spring until they are flush with the table level

Load-bearing capacity: up to 27 kN/m, flexible ball spacing

Any variable length in one-piece design up to 2900 mm.

Fastening of the ball bar using a fastening crossbar or a wedge lock.

## Roller bar with spring pack

for medium loads, for linear movement of dies:

Function and design of the roller bar similar to spring-loaded ball bars.

Load-bearing capacity slightly increased thanks to the use of rollers.

Load-bearing capacity up to 66 kN/m, flexible roller spacing and orientation.

Any variable length in one-piece design up to 2900 mm.

Fastening of the roller bar using a fastening crossbar or a wedge lock.

## Ball and roller inserts with spring pack

For installation in tables without T-slots:

The spring-loaded ball and roller inserts are individually inserted into drilled holes. The function is similar to that of ball or roller bars with a spring pack.

Load-bearing capacity up to 2200 N, stroke up to 3 mm.

# Ball bar, hydraulically lifted (max. 100 bar)

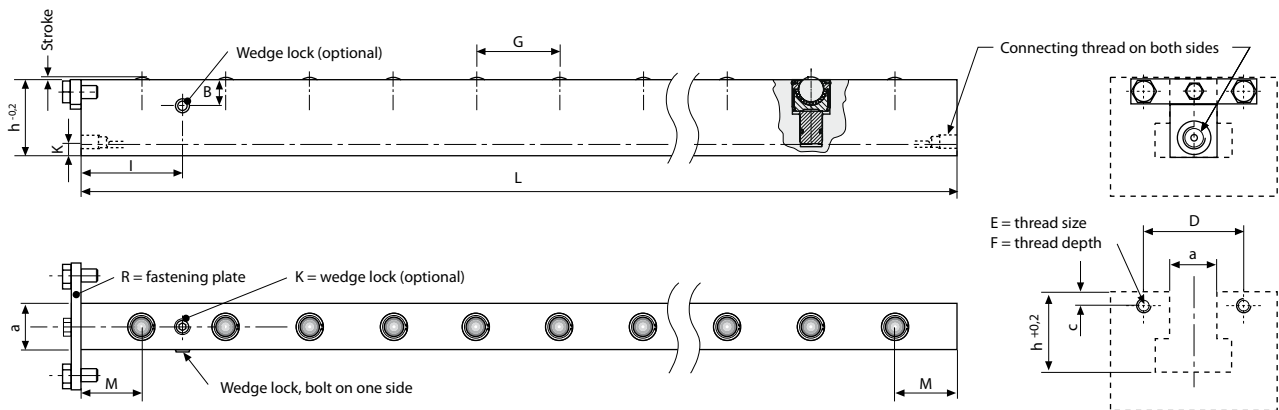

**Tmax.: 100°C**

Higher temperatures on request

Slot with (a) (mm)	18	22	28	36	1 3/16"	1 1/16"
Min. slot height (h) (mm)	29,5	38	42	53	29,4	37,4
Standard slot height (h) (mm)	30	38	48	61	29,4	38,9
Ball spacing G min. (mm)	26	32	37	43	26	32
<b>Ball spacing G standard (mm)</b>	<b>30</b>	<b>40</b>	<b>45</b>	<b>50</b>	<b>30</b>	<b>40</b>
Ball spacing G max. (mm)	60	80	90	100	60	80
L min. (mm)	*)	*)	*)	*)	*)	*)
L max. (mm)	2900	2900	2900	2900	2900	2900
Hub (mm)	1	2	2	2	1	2
Load-bearing capacity ball (kN)	0,79	1,1	1,5	2,5	0,79	1,1
Connecting thread	G 1/8	G 1/8	G 1/4	G 1/4	G 1/8	G 1/4
Oil consumption / ball insert (cm <sup>3</sup> )	0,08	0,23	0,31	0,51	0,08	0,23
B (mm)	12	16	16	16	12	16
C (mm)	5	7	9	10	5	7
D (mm)	36	40	50	55	36	40
E (mm)	M5	M5	M6	M6	M5	M5
F (mm)	15	15	20	20	15	15
I (mm)	35	46	51	56,5	35	46
K (mm)	8	8,5	11	11	8	11
M (mm)	22,5	30	32,5	35	22,5	30

\*) L min. depends on the ball spacing G with at least 3 balls

Indication of the load per ball bar; Annex K = wedge lock,

R = fastening plate

A fastening plate, a short 250 mm hose and an angular swivel type scrow fitting are supplied with the ball bar.

## Example of ordering:

**8.9217.7128 L1415 K** without suffix  
 Ball bar Slot Length | Standard Standard  
 hydraulic 28 mm 1415 mm | slot height ball spacing  
 Fastening of  
 wedge lock

## Example of ordering:

**8.9217.7128 L1445 R H44 G60**  
 Ball bar Slot Length | Slot Ball spacing  
 hydraulic 28 mm 1445 mm | height 60 mm  
 44 mm  
 Fastening of  
 fastening plate

## Ball bar variations with hydraulic lifting (max. 100 bar)

If the appropriate ball bar for your specific application is not included in the tables of standard bars, our range of variations offers a solution. Fewer balls also means that the ball bar will be offered at a lower price. Select the slot height, the ball spacing and the bar length to create a variation for your application.

e.g. **a = 28 mm**  
 e.g. **example of fastening = R**

## Within the limits indicated in the table of dimensions the following parameters can be freely selected:

### Slot height (h)

If for your application the slots are not as high as in our standard design, indicate the corresponding dimension.

If for your application the slots are higher than our standard design, spacer bars may be inserted.

e.g. **h = 44 mm**

### Spacing of balls (G) and load-bearing capacity of the ball bar

By changing the spacing of the balls the load-bearing capacity of the ball bar may be varied. Please note that the load-bearing capacity is indicated for the full length of the ball bar. Therefore, both the load-bearing capacity and the ball spacing must be selected to suit the die weight and the die supporting length.

Please indicate the desired ball spacing or load-bearing capacity of the ball bar, or the maximum die weight and the die dimensions.

e.g. **G = 60 mm**

or **load-bearing capacity/bar = 36 kN**  
 or **number of balls = 24**  
 or **die weight and outside dimensions**

### Length of the ball bar (L)

The possible length of the bar is obtained from the ball spacing (G) and the parameter (M).

Just indicate the theoretical length (e.g. the length of the table) for your ball bar.

Please note that a ball bar must be equipped with at least 3 balls.

\*) e.g. **L = 1445 mm**

Based on these parameters, we will devise the ball bar for your specific application.

Please contact us, we will be pleased to offer you advice!

Subject to technical modification

**Hilma-Römheld GmbH**

Schützenstraße 74 · D-57271 Hilchenbach

Phone +49 (0) 2733 / 281-0 · Fax +49 (0) 2733 / 281-113 · www.hilma.de

**8.18341**



### Selection of ball bars in preferred sizes: slot height „h“ and ball spacing „G“

For other slot heights, lengths and load bearing capacities (or ball spacings), see range of variations page 1.

Part no.	Slot (a) (mm)	Length (L) (mm)	Max. load (kN)	Number of balls
8.9217.7118 L 105 R	18	105	2,3	3
8.9217.7118 L 135 R	18	135	3,1	4
8.9217.7118 L 165 R	18	165	3,9	5
8.9217.7118 L 195 R	18	195	4,7	6
8.9217.7118 L 255 R	18	255	6,3	8
8.9217.7118 L 315 R	18	315	7,9	10
8.9217.7118 L 375 R	18	375	9,4	12
8.9217.7118 L 435 R	18	435	11,0	14
8.9217.7118 L 495 R	18	495	12,6	16
8.9217.7118 L 555 R	18	555	14,2	18
8.9217.7118 L 615 R	18	615	15,8	20
8.9217.7118 L 675 R	18	675	17,3	22
8.9217.7118 L 735 R	18	735	18,9	24
8.9217.7118 L 795 R	18	795	20,5	26
8.9217.7118 L 855 R	18	855	22,1	28
8.9217.7118 L 915 R	18	915	23,7	30
Other intermediate lengths up to max. 2895 are possible.				
8.9217.7118 L 2895 R	18	2895	75,8	96
Other intermediate lengths up to max. 2900 are possible.				
8.9217.7122 L 140 R	22	140	3,3	3
8.9217.7122 L 180 R	22	180	4,4	4
8.9217.7122 L 220 R	22	220	5,5	5
8.9217.7122 L 260 R	22	260	6,6	6
8.9217.7122 L 340 R	22	340	8,8	8
8.9217.7122 L 420 R	22	420	11,0	10
8.9217.7122 L 500 R	22	500	13,2	12
8.9217.7122 L 580 R	22	580	15,4	14
8.9217.7122 L 660 R	22	660	17,6	16
8.9217.7122 L 740 R	22	740	19,8	18
8.9217.7122 L 780 R	22	780	20,9	19
8.9217.7122 L 820 R	22	820	22,0	20
8.9217.7122 L 900 R	22	900	24,2	22
8.9217.7122 L 980 R	22	980	26,4	24
8.9217.7122 L 1060 R	22	1060	28,6	26
8.9217.7122 L 1140 R	22	1140	30,8	28
8.9217.7122 L 1220 R	22	1220	33,0	30
8.9217.7122 L 1300 R	22	1300	35,2	32
Other intermediate lengths up to max. 2900 are possible.				
8.9217.7122 L 2940 R	22	2900	79,2	72
Other intermediate lengths up to max. 2900 are possible.				
8.9217.7128 L 155 R	28	155	4,5	3
8.9217.7128 L 200 R	28	200	6,0	4
8.9217.7128 L 245 R	28	245	7,5	5
8.9217.7128 L 290 R	28	290	9,0	6
8.9217.7128 L 380 R	28	380	12,0	8
8.9217.7128 L 470 R	28	470	15,0	10
8.9217.7128 L 560 R	28	560	18,0	12
8.9217.7128 L 650 R	28	650	21,0	14
8.9217.7128 L 695 R	28	695	22,5	15
8.9217.7128 L 740 R	28	740	24,0	16
8.9217.7128 L 830 R	28	830	27,0	18
8.9217.7128 L 920 R	28	920	30,0	20
8.9217.7128 L 965 R	28	965	31,5	21
8.9217.7128 L 1010 R	28	1010	33,0	22
8.9217.7128 L 1100 R	28	1100	36,0	24
8.9217.7128 L 1190 R	28	1190	39,0	26
8.9217.7128 L 1280 R	28	1280	42,0	28
Other intermediate lengths up to max. 2900 are possible.				
8.9217.7128 L 2945 R	28	2900	96	64

▶ available at short notice

Part no.	Slot (a) (mm)	Length (L) (mm)	Max. load (kN)	Number of balls
8.9217.7136 L 170 R	36	170	7,5	3
8.9217.7136 L 220 R	36	220	10,0	4
8.9217.7136 L 270 R	36	270	12,5	5
8.9217.7136 L 320 R	36	320	15,0	6
8.9217.7136 L 420 R	36	420	20,0	8
8.9217.7136 L 520 R	36	520	25,0	10
8.9217.7136 L 620 R	36	620	30,0	12
8.9217.7136 L 720 R	36	720	35,0	14
8.9217.7136 L 820 R	36	820	40,0	16
8.9217.7136 L 920 R	36	920	45,0	18
8.9217.7136 L 1020 R	36	1020	50,0	20
8.9217.7136 L 1120 R	36	1120	55,0	22
8.9217.7136 L 1220 R	36	1220	60,0	24
8.9217.7136 L 1320 R	36	1320	65,0	26
Other intermediate lengths up to max. 2870 are possible.				
8.9217.7136 L 2920 R	36	2870	142,5	57
Other intermediate lengths up to max. 2895 are possible.				
8.9217.7113 L 105 R	13/16"	105	2,3	3
8.9217.7113 L 135 R	13/16"	135	3,1	4
8.9217.7113 L 165 R	13/16"	165	3,9	5
8.9217.7113 L 195 R	13/16"	195	4,7	6
8.9217.7113 L 255 R	13/16"	255	6,3	8
8.9217.7113 L 315 R	13/16"	315	7,9	10
8.9217.7113 L 375 R	13/16"	375	9,4	12
8.9217.7113 L 435 R	13/16"	435	11,0	14
8.9217.7113 L 495 R	13/16"	495	12,6	16
8.9217.7113 L 555 R	13/16"	555	14,2	18
8.9217.7113 L 615 R	13/16"	615	15,8	20
8.9217.7113 L 675 R	13/16"	675	17,3	22
8.9217.7113 L 735 R	13/16"	735	18,9	24
8.9217.7113 L 795 R	13/16"	795	20,5	26
8.9217.7113 L 855 R	13/16"	855	22,1	28
8.9217.7113 L 915 R	13/16"	915	23,7	30
Other intermediate lengths up to max. 2895 are possible.				
8.9217.7113 L 2925 R	13/16"	2895	75,8	96
Other intermediate lengths up to max. 2900 are possible.				
8.9217.7117 L 140 R	1 1/16"	140	3,3	3
8.9217.7117 L 180 R	1 1/16"	180	4,4	4
8.9217.7117 L 220 R	1 1/16"	220	5,5	5
8.9217.7117 L 260 R	1 1/16"	260	6,6	6
8.9217.7117 L 340 R	1 1/16"	340	8,8	8
8.9217.7117 L 420 R	1 1/16"	420	11,0	10
8.9217.7117 L 500 R	1 1/16"	500	13,2	12
8.9217.7117 L 580 R	1 1/16"	580	15,4	14
8.9217.7117 L 660 R	1 1/16"	660	17,6	16
8.9217.7117 L 740 R	1 1/16"	740	19,8	18
8.9217.7117 L 820 R	1 1/16"	820	22,0	20
8.9217.7117 L 900 R	1 1/16"	900	24,2	22
8.9217.7117 L 980 R	1 1/16"	980	26,4	24
8.9217.7117 L 1060 R	1 1/16"	1060	28,6	26
8.9217.7117 L 1140 R	1 1/16"	1140	30,8	28
8.9217.7117 L 1220 R	1 1/16"	1220	33,0	30
8.9217.7117 L 1300 R	1 1/16"	1300	35,2	32
Other intermediate lengths up to max. 2900 are possible.				
8.9217.7117 L 2940 R	1 1/16"	2900	79,2	72

▼  
R = fastening plate  
K = wedge lock

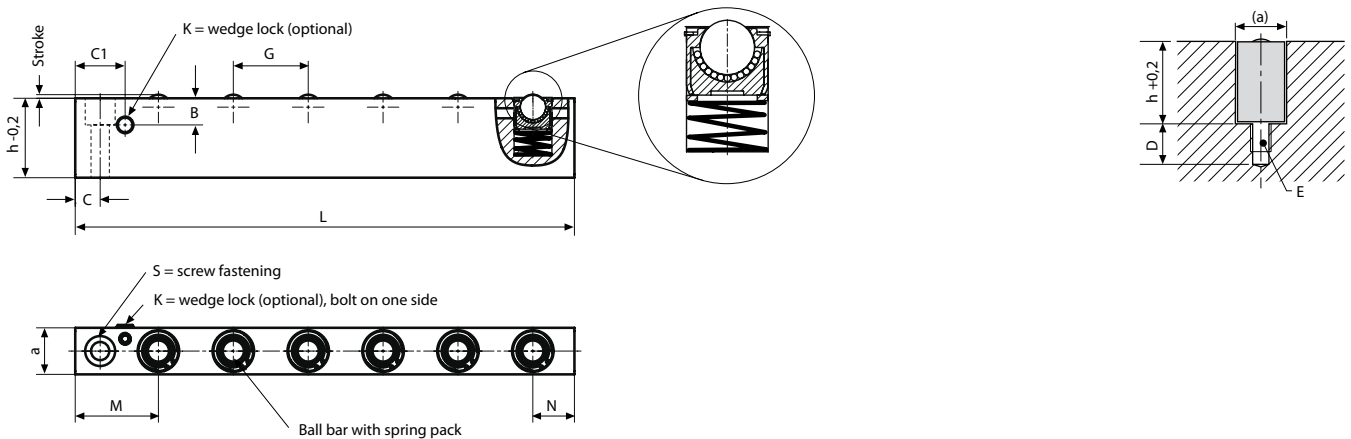

**Tmax.: 100°C**  
Higher temperatures on request

Slot with (a) (mm)	18	22	28	36	13/16"	1 1/16"
Min. slot height (h) (mm)	29,4	38	48	46	29,4	38
Standard slot height (h) (mm)	30	38	48	61	29,4	38,9
Ball spacing G min. (mm)	20	23	28	34	20	23
<b>Ball spacing G standard (mm)</b>	<b>30</b>	<b>40</b>	<b>45</b>	<b>50</b>	<b>30</b>	<b>40</b>
Ball spacing G max. (mm)	60	80	90	100	60	80
L min. (mm)	*)	*)	*)	*)	*)	*)
L max. (mm)	2900	2900	2900	2900	2900	2900
Hub (mm)	1	2	2	2	1	2
Load-bearing capacity ball (kN)	0,22	0,42	0,63	1,00	0,22	0,42
B (mm)	12	16	16	16	12	16
C (mm)	10	12,5	15	20	10	12,5
C1 (mm)	10	24,5	30	35	10	24,5
D (mm)	15	15	20	20	15	15
E (mm)	M6	M8	M10	M10	M6	M8
M (mm)	27,5	40	50	57,5	27,5	40
N (mm)	12,5	15	25	27,5	12,5	15

\*) L min. depends on the ball spacing G with at least 3 balls  
Indication of the load per ball bar; Annex K = wedge lock, S = screw fastening

### Example of an order:

**8.9218. 7236 L1385 K** without suffix  
 Ball bar Slot Length Standard Standard ball  
 spring-loaded 36 mm 1385 mm slot height spacing  
 Fastening of wedge lock

### Example of an order:

**8.9218. 7236 L1380 S H50 G35**  
 Ball bar Slot Length Slot Ball spacing  
 spring-loaded 36 mm 1380 mm height 50 mm 35 mm  
 Fastening of screw

Based on these parameters, we will devise the ball bar for your specific application.  
Please contact us, we will be pleased to offer you advice!

### Ball bar variations with spring pack

If the appropriate ball bar for your specific application is not included in the tables of standard bars, our range of variations offers a solution. Fewer balls also means that the ball bar will be offered at a lower price. Select the slot height, the ball spacing and the bar length to create a variation for your application.

e.g. **a = 36 mm**  
e.g. **fastening screw = S**

### Within the limits indicated in the table of dimensions the following parameters can be freely selected:

#### Slot height (h)

If for your application the slots are not as high as in our standard design, indicate the corresponding dimension.  
If for your application the slots are higher than our standard design, spacer bars may be inserted.

e. g. **h = 50 mm**

#### Spacing of balls (G) and load-bearing capacity of the ball bar

By changing the spacing of the balls the load-bearing capacity of the ball bar may be varied. Please note that the load-bearing capacity is indicated for the full length of the ball bar. Therefore, both the load-bearing capacity and the ball spacing must be selected to suit the die weight and the die supporting length.  
Please indicate the desired ball spacing or load-bearing capacity of the ball bar, or the maximum die weight and the die dimensions.

e.g. **G = 35 mm**

or **load-bearing capacity/bar = 38 kN**  
or **number of balls = 38**  
or **die weight and outside dimensions**

#### Length of the ball bar (L)

The possible length of the bar is obtained from the ball spacing (G) and the parameter (M).

Just indicate the theoretical length (e.g. the length of the table) for your ball bar.

Please note that a ball bar must be equipped with at least 3 balls.

\*) e.g. **L = 1380 mm**



### Selection of ball bars in preferred sizes: slot height „h“ and ball spacing „G“

For other slot heights, lengths and load-bearing capacities (or ball spacing), see range of variations page 1.

Part no.	Slot (a) (mm)	Length (L) (mm)	Max. load (kN)	Number of balls
8.9218.7218 L 100 S	18	100	0,6	3
8.9218.7218 L 130 S	18	130	0,8	4
8.9218.7218 L 160 S	18	160	1,1	5
8.9218.7218 L 190 S	18	190	1,3	6
8.9218.7218 L 250 S	18	250	1,7	8
▶ 8.9218.7218 L 310 S	18	310	2,2	10
8.9218.7218 L 370 S	18	370	2,6	12
8.9218.7218 L 430 S	18	430	3	14
▶ 8.9218.7218 L 490 S	18	490	3,5	16
8.9218.7218 L 550 S	18	550	3,9	18
8.9218.7218 L 610 S	18	610	4,4	20
8.9218.7218 L 670 S	18	670	4,8	22
8.9218.7218 L 730 S	18	730	5,2	24
Other intermediate lengths up to max. 2890 are possible.				
8.9218.7218 L 2890 S	18	2890	21,1	96
8.9218.7222 L 135 S	22	135	1,2	3
8.9218.7222 L 175 S	22	175	1,6	4
8.9218.7222 L 215 S	22	215	2,1	5
8.9218.7222 L 255 S	22	255	2,5	6
8.9218.7222 L 335 S	22	335	3,3	8
8.9218.7222 L 415 S	22	415	4,2	10
▶ 8.9218.7222 L 495 S	22	495	5	12
8.9218.7222 L 575 S	22	575	5,8	14
8.9218.7222 L 655 S	22	655	6,7	16
8.9218.7222 L 735 S	22	735	7,5	18
8.9218.7222 L 815 S	22	815	8,4	20
▶ 8.9218.7222 L 895 S	22	895	9,2	22
8.9218.7222 L 975 S	22	975	10	24
8.9218.7222 L 1055 S	22	1055	10,9	26
8.9218.7222 L 1135 S	22	1135	11,7	28
8.9218.7222 L 1215 S	22	1215	12,6	30
8.9218.7222 L 1295 S	22	1295	13,4	32
Other intermediate lengths up to max. 2895 are possible.				
8.9218.7222 L 2895 S	22	2895	30,2	72
8.9218.7228 L 165 S	28	165	1,8	3
8.9218.7228 L 210 S	28	210	2,5	4
8.9218.7228 L 255 S	28	255	3,1	5
8.9218.7228 L 300 S	28	300	3,7	6
8.9218.7228 L 390 S	28	390	5	8
8.9218.7228 L 480 S	28	480	6,3	10
8.9218.7228 L 570 S	28	570	7,5	12
8.9218.7228 L 660 S	28	660	8,8	14
8.9218.7228 L 750 S	28	750	10	16
8.9218.7228 L 840 S	28	840	11,3	18
8.9218.7228 L 930 S	28	930	12,6	20
8.9218.7228 L 1020 S	28	1020	13,8	22
Other intermediate lengths up to max. 2865 are possible.				
8.9218.7228 L 2865 S	28	2865	39,6	63

Part no.	Slot (a) (mm)	Length (L) (mm)	Max. load (kN)	Number of balls
8.9218.7136 L 185 S	36	185	3	3
8.9218.7136 L 235 S	36	235	4	4
8.9218.7136 L 285 S	36	285	5	5
8.9218.7136 L 335 S	36	335	6	6
8.9218.7136 L 435 S	36	435	8	8
8.9218.7136 L 535 S	36	535	10	10
8.9218.7136 L 635 S	36	635	12	12
8.9218.7136 L 735 S	36	735	14	14
8.9218.7136 L 835 S	36	835	16	16
8.9218.7136 L 935 S	36	935	18	18
8.9218.7136 L 1035 S	36	1035	20	20
8.9218.7136 L 1135 S	36	1135	22	22
Other intermediate lengths up to max. 2885 are possible.				
8.9218.7136 L 2985 S	36	2885	57	57
8.9218.7213 L 100 S	13/16"	100	0,6	3
8.9218.7213 L 130 S	13/16"	130	0,8	4
8.9218.7213 L 160 S	13/16"	160	1,1	5
8.9218.7213 L 190 S	13/16"	190	1,3	6
8.9218.7213 L 250 S	13/16"	250	1,7	8
8.9218.7213 L 310 S	13/16"	310	2,2	10
8.9218.7213 L 370 S	13/16"	370	2,6	12
8.9218.7213 L 430 S	13/16"	430	3	14
8.9218.7213 L 490 S	13/16"	490	3,5	16
8.9218.7213 L 550 S	13/16"	550	3,9	18
8.9218.7213 L 610 S	13/16"	610	4,4	20
8.9218.7213 L 670 S	13/16"	670	4,8	22
8.9218.7213 L 730 S	1 13/16"	730	5,2	24
Other intermediate lengths up to max. 2890 are possible.				
8.9218.7213 L 2890 S	13/16"	2890	21,1	96
8.9218.7217 L 135 S	1 1/16"	135	1,2	3
8.9218.7217 L 175 S	1 1/16"	175	1,6	4
8.9218.7217 L 215 S	1 1/16"	215	2,1	5
8.9218.7217 L 255 S	1 1/16"	255	2,5	6
8.9218.7217 L 335 S	1 1/16"	335	3,3	8
8.9218.7217 L 415 S	1 1/16"	415	4,2	10
8.9218.7217 L 495 S	1 1/16"	495	5	12
8.9218.7217 L 575 S	1 1/16"	575	5,8	14
8.9218.7217 L 655 S	1 1/16"	655	6,7	16
8.9218.7217 L 735 S	1 1/16"	735	7,5	18
8.9218.7217 L 815 S	1 1/16"	815	8,4	20
8.9218.7217 L 895 S	1 1 1/16"	895	9,2	22
8.9218.7217 L 975 S	1 1/16"	975	10	24
8.9218.7217 L 1055 S	1 1/16"	1055	10,9	26
8.9218.7217 L 1135 S	1 1/16"	1135	11,7	28
8.9218.7217 L 1215 S	1 1/16"	1215	12,6	30
8.9218.7217 L 1295 S	1 1/16"	1295	13,4	32
Other intermediate lengths up to max. 2895 are possible.				
8.9218.7217 L 2895 S	1 1/16"	2895	30,2	72

▼ S = screw  
K = wedge lock

▶ available at short notice



**Roller insert**



without flange

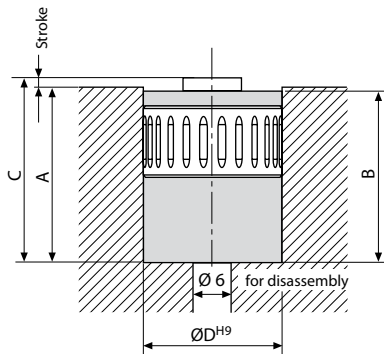

**Design without flange**

Max. load (N)	600	900	1400	2400
*Stroke (mm)	1,5	2,0	2,0	2,0
A (mm)	30,0 +0,1	32,0 +0,1	43,5 +0,1	52,5 +0,1
B (mm)	29,9	31,9	43,4	52,4
C (mm)	31,5	34,0	45,5	54,5
Ø D (mm)	20	24	30	40
<b>Part no.</b>	<b>8.1210.0605</b>	<b>8.1210.0611</b>	<b>8.1210.0618</b>	<b>8.1210.0622</b>

\* Other strokes available on request



with flange

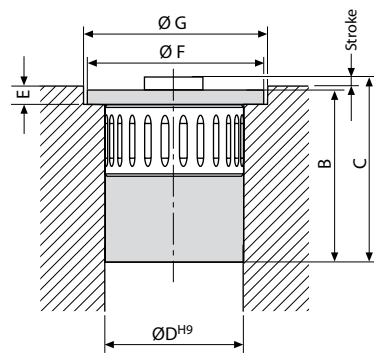

**Design with flange**

Max. load (N)	600	900	1400	2400
*Stroke (mm)	1,5	2,0	2,0	2,0
B (mm)	29,9 +0,1	31,9 +0,1	43,4 +0,1	52,4 +0,1
C (mm)	31,5	34,0	45,5	54,5
Ø D (mm)	20	24	30	40
E (mm)	3,5 +0,1	3,5 +0,1	4,5 +0,1	5,5 +0,1
Ø F (mm)	24,5	29,5	34,5	47,5
Ø G (mm)	25 +0,2	30 +0,2	35 +0,2	48 +0,2
<b>Part no.</b>	<b>8.1210.0606</b>	<b>8.1210.0612</b>	<b>8.1210.0619</b>	<b>8.1210.0623</b>

\* Other strokes available on request

**Ball insert**



without flange

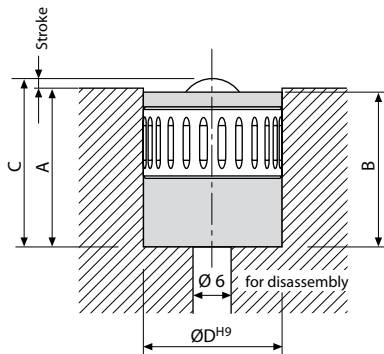

**Design without flange**

Max. load (N)	200	400	600	1000
*Stroke (mm)	1,5	1,5	2,0	3,0
A (mm)	24,0 +0,1	28,5 +0,1	34,0 +0,1	45,0 +0,1
B (mm)	23,6	28,5	34,0	44,8
C (mm)	25,5	30,0	36,0	48,0
Ø D (mm)	20	24	30	40
<b>Part no.</b>	<b>8.1210.0005</b>	<b>8.1210.0011</b>	<b>8.1210.0018</b>	<b>8.1210.0022</b>

\* Other strokes available on request



with flange

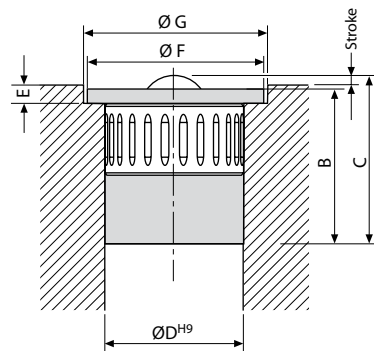

**Design with flange**

Max. load (N)	200	400	600	1000
*Stroke (mm)	1,5	1,5	2,0	2,0
B (mm)	23,5	28,5	34,0	44,0
C (mm)	25,2	30,2	36,0	46,0
Ø D (mm)	20	24	30	40
E (mm)	3,5 +0,1	4,0 +0,1	4,5 +0,1	5,6 +0,1
Ø F (mm)	24,5	29,5	34,5	47,5
Ø G (mm)	25 +0,2	30 +0,2	35 +0,2	48 +0,2
<b>Part no.</b>	<b>8.1210.0006</b>	<b>8.1210.0012</b>	<b>8.1210.0019</b>	<b>8.1210.0023</b>

\* Other strokes available on request