

# Roller and ball bars for easy and safe die change



# HILMA

## T-slot tolerances acc. to DIN 650

a	b	c	h min.	h max.	n max.
18 H8	30 <sup>+2</sup>	12 <sup>+2</sup>	30	36	1,6
22 H8	37 <sup>+3</sup>	16 <sup>+2</sup>	38	45	1,6
28 H8	46 <sup>+4</sup>	20 <sup>+2</sup>	48	56	1,6
36 H8	56 <sup>+4</sup>	25 <sup>+3</sup>	61	71	2,5

Dimensions in mm

$h_{min.}$  = smallest dimension acc. to DIN 650

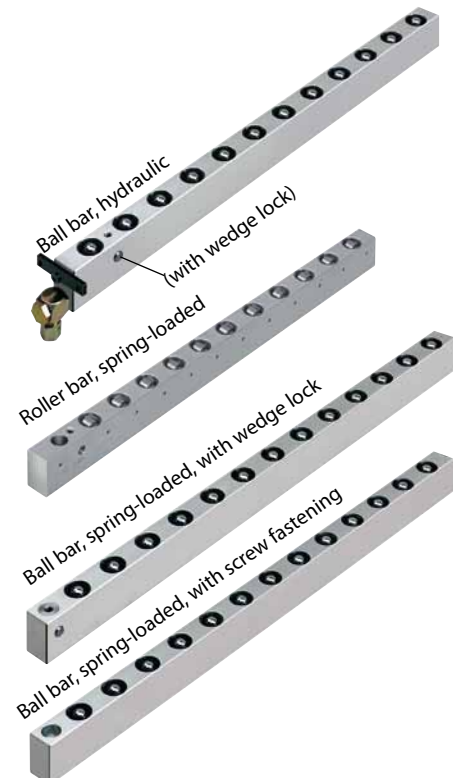
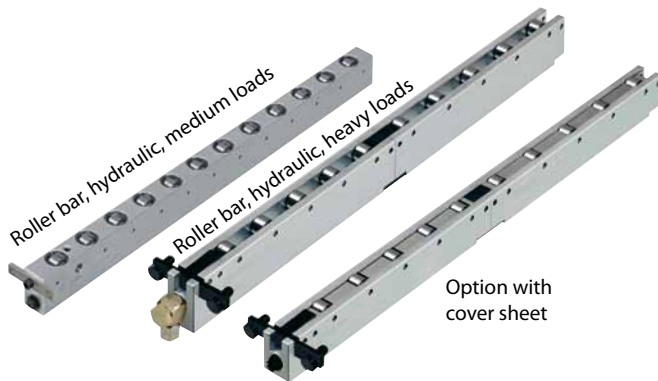
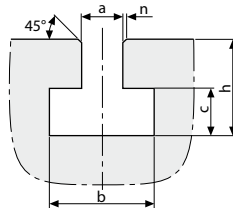

Load: 20 - 100 kg  
Hole: 20 - 40 mm

Load: 40 - 220 kg  
Hole: 20 - 40 mm

## Applications:

- in T-slots and rectangular slots of press beds for easy die change
- die change rationalisation

## Roller bar, hydraulically lifted

for heavy loads, for linear movement of dies:

On the underside of the roller bar lifting pistons are provided. Pressure is applied to these pistons using hydraulic pressure generators, which lift then the complete roller bar. The die positioned on the roller bars is not in contact with the table top and can be easily moved and positioned. The basic bodies are made from a high-strength and robust aluminium alloy.

Max. operating pressure: 400 bar

Load-bearing capacity: up to 160 kN/m, roller spacing 50 mm.

Any length up to 2500 mm is possible using modular segments

Fastening of the roller bar using a fastening plate.

## Roller bar, hydraulically lifted

for medium loads, for linear movement of dies:

Other than in the case of the above roller bar version, lifting pistons are provided below each roller allowing each roller to be lifted individually.

The basic body of the bar remains in its position. They are made from a high-strength aluminium alloy

Max. operating pressure: 120 bar.

Load-bearing capacity: up to 99 kN/m, flexible roller spacing and orientation.

Any length in a single piece design up to 2900 mm.

Fastening of the roller bar using a fastening plate or a wedge lock.

## Ball bar, hydraulically lifted for medium loads, for flexible horizontal movement of dies:

Oil pressure is applied using a hydraulic pressure generator to lift each ball bar individually. The die positioned on the ball bars is not in contact with the table top and can be easily moved.

Max. operating pressure: 100 bar

Load-bearing capacity: up to 55 kN/m, flexible ball spacing.

Any length in a single piece design up to 2900 mm.

Fastening of the ball bar using a fastening plate or a wedge lock.

## Ball bar with spring pack for lightweight loads for flexible horizontal movement of dies:

When preloaded, the balls project over the table level by up to 2 mm.

If the die is clamped, the balls are pressed into the bar body against the spring until they are flush with the table level

Load-bearing capacity: up to 27 kN/m, flexible ball spacing

Any variable length in one-piece design up to 2900 mm.

Fastening of the ball bar using a fastening crossbar or a wedge lock.

## Roller bar with spring pack

for medium loads, for linear movement of dies:

Function and design of the roller bar similar to spring-loaded ball bars.

Load-bearing capacity slightly increased thanks to the use of rollers.

Load-bearing capacity up to 66 kN/m, flexible roller spacing and orientation.

Any variable length in one-piece design up to 2900 mm.

Fastening of the roller bar using a fastening crossbar or a wedge lock.

## Ball and roller inserts with spring pack

For installation in tables without T-slots:

The spring-loaded ball and roller inserts are individually inserted into drilled holes. The function is similar to that of ball or roller bars with a spring pack.

Load-bearing capacity up to 2200 N, stroke up to 3 mm.

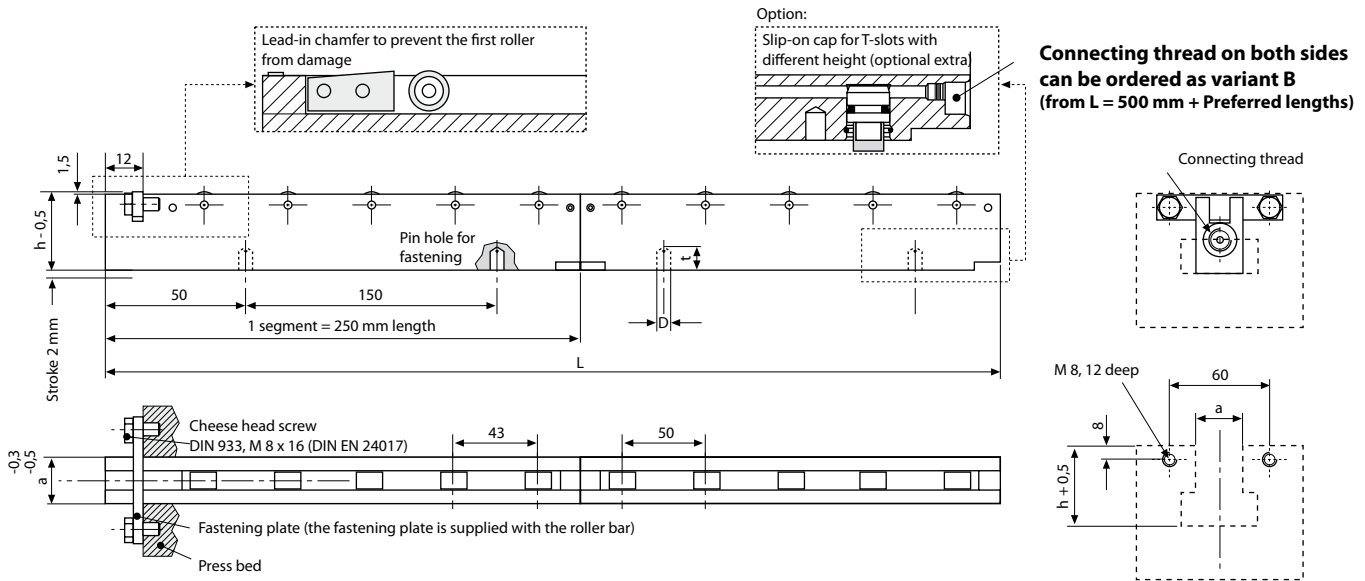

	Slot (a) (mm)	22	28	36
Height (h) (mm)		38	48	61
Slot height max. (h) (mm)		45	59	72
Max. load/ roller (in kN)		6,0	6,4	8,0
Number of rollers per segment = 250 mm		5	5	5
Connecting thread		G ½	G ½	G ¼
Max. operating pressure (bar)		400	400	400
Roller diameter Ø (mm)		16 x 12	16 x 12	19 x 12
Stroke (mm)		2	2	2
Oil requirement / segment (cm <sup>3</sup> )		1,54	1,60	2,00
D (mm)		6,5	8,5	8,5
t (mm)		9	12	12

Other heights and lengths are available on request.

**Max. temperature 100°C.** Inch dimensions on request

**Connecting thread on both sides can be ordered as variant B (from L = 500 mm + Preferred lengths)**

Part no.	Slot (a) (mm)	Length (L) (mm)	Max. load (kN) at 400 bar
<b>8.1834.5100L250</b>	22	250	30
8.1834.5110L300	22	300	36
8.1834.5110L350	22	350	42
8.1834.5110L400	22	400	48
8.1834.5110L450	22	450	54
<b>8.1834.5110L500</b>	22	500	60
8.1834.5115L550	22	550	66
8.1834.5115L600	22	600	72
8.1834.5115L650	22	650	78
8.1834.5115L700	22	700	84
<b>8.1834.5115L750</b>	22	750	90
8.1834.5120L800	22	800	96
8.1834.5120L850	22	850	102
8.1834.5120L900	22	900	108
<b>8.1834.5120L1000</b>	22	1000	120
8.1834.5130L1100	22	1100	132
<b>8.1834.5130L1250</b>	22	1250	150
8.1834.5140L1350	22	1350	162
<b>8.1834.5140L1500</b>	22	1500	180
8.1834.5150L1750	22	1750	210
<b>8.1834.5180L2500</b>	22	2500*	340

\* two-piece design

Dimensions printed in bold are the preferred lengths. On request these are available with a steel sheet cover.

Part no.	Slot (a) (mm)	Length (L) (mm)	Max. load (kN) at 400 bar
<b>8.1834.6100L250</b>	28	250	32
8.1834.6110L300	28	300	40
8.1834.6110L350	28	350	48
8.1834.6110L400	28	400	48
8.1834.6110L450	28	450	56
<b>8.1834.6110L500</b>	28	500	64
8.1834.6115L550	28	550	72
8.1834.6115L600	28	600	80
8.1834.6115L650	28	650	80
8.1834.6115L700	28	700	88
<b>8.1834.6115L750</b>	28	750	96
8.1834.6120L800	28	800	104
8.1834.6120L850	28	850	112
8.1834.6120L900	28	900	112
<b>8.1834.6120L1000</b>	28	1000	128
8.1834.6130L1100	28	1100	144
<b>8.1834.6130L1250</b>	28	1250	160
8.1834.6140L1350	28	1350	176
<b>8.1834.6140L1500</b>	28	1500	192
<b>8.1834.6150L1750</b>	28	1750	220
<b>8.1834.6160L2000</b>	28	2000	250
<b>8.1834.6180L2500</b>	28	2500*	314

Part no.	Slot (a) (mm)	Length (L) (mm)	Max. load (kN) at 400 bar
<b>8.1834.7110L500</b>	36	500	80
8.1834.7115L600	36	600	96
<b>8.1834.7115L750</b>	36	750	120
8.1834.7120L850	36	850	136
8.1834.7120L900	36	900	144
<b>8.1834.7120L1000</b>	36	1000	160
8.1834.7130L1100	36	1100	176
<b>8.1834.7130L1250</b>	36	1250	200
8.1834.7140L1350	36	1350	216
<b>8.1834.7140L1500</b>	36	1500	240
<b>8.1834.7150L1750</b>	36	1750	280
<b>8.1834.7160L2000</b>	36	2000	320
<b>8.1834.7180L2500</b>	36	2500*	400

Fastening plate, short hose 250 mm and angular swivel-type screw fitting are supplied with the bar.

# Roller bar for medium loads, hydraulic lifting of individual rollers (max. 120 bar)

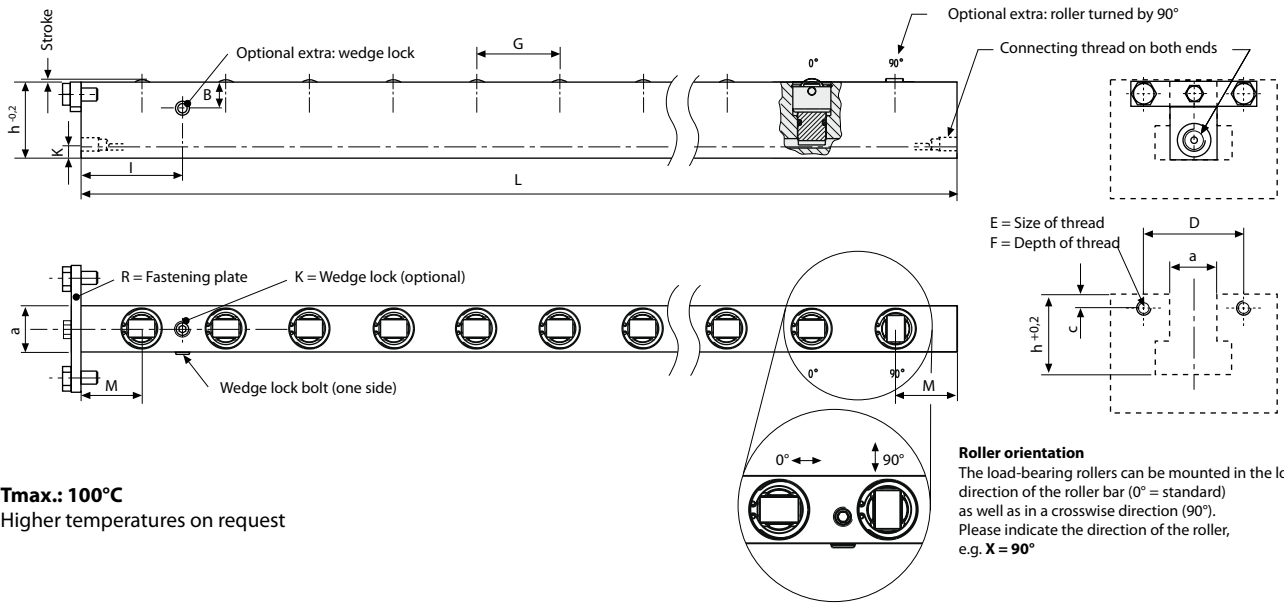

**Tmax.: 100°C**  
Higher temperatures on request

Slot (a) (mm)	18	22	28	36	1 3/16"	1 1/16"
Slot height (h) (mm)	29,5	37,5	43	54,5	29,4	38
Standard slot height (h) (mm)	30	38	48	61	29,4	38,9
Roller spacing G min. (mm)	26	32	37	43	26	32
<b>Roller spacing G standard (mm)</b>	<b>30</b>	<b>40</b>	<b>45</b>	<b>50</b>	<b>30</b>	<b>40</b>
Roller spacing G max. (mm)	60	80	90	100	60	80
L min. (*)	*)	*)	*)	*)	*)	*)
L max.	2900	2900	2900	2900	2900	2900
Stroke (mm)	1	2	2	2	1	2
Load-bearing capacity/roller (kN)	1,14	1,85	3,0	4,5	1,14	1,85
Connecting thread	G 1/8	G 1/8	G 1/4	G 1/4	G 1/8	G 1/4
Oil requirement/l roller insert (cm³)	0,10	0,31	0,51	0,76	0,10	0,31
B (mm)	12	16	16	16	12	16
C (mm)	5	7	9	10	5	7
D (mm)	36	40	50	55	36	40
E (mm)	M5	M5	M6	M6	M5	M5
F (mm)	15	15	20	20	15	15
I (mm)	35	46	51	56,5	35	46
K (mm)	8	8,5	11	11	8	11
M (mm)	22,5	30	32,5	35	22,5	30

\*) L min. depends on the roller spacing G between at least 3 rollers.  
Load-bearing capacity indicated per bar.

K = Wedge lock  
R = Fastening plate  
Fastening plate, short hose (250 mm long) and angular screw fitting are supplied with the bar.

## Example of an order:

**8.9215. 7028 L 1415 K** without suffix

Roller bar, Slot Length Standard Standard Standard  
hydraulic 28 mm 1415 mm roller height roller spacing roller orientation (0°)

Fastening of wedge lock

## Example of an order:

**8.9215. 7028 L 1445 R H43 G60 X**

Roller bar, Slot Length Slot Roller Roller  
hydraulic 28 mm 1445 mm height spacing orientation  
Fastening of fastening plate

By means of these parameters we will determine the roller bar for your specific application. Please contact us, we will be pleased to give you any advice you may require.

## Roller bar versions, hydraulically lifted (max. 120 bar)

If an appropriate roller bar suitable for your specific application is not included in the table of standard bars, our range of variations will offer a solutions.

Fewer rollers also means that the roller bar will be offered at a lower price. Select the slot height, the roller spacing and the bar length to create the correct variation for your application.

e.g.. **a = 28 mm**  
e.g.. **fastening plate = R**

## Within the limits stated in the table of dimensions, the following parameters can be freely selected:

### Slot height (h)

If, in your application, the slot height does not correspond to our standard design, please indicate the required dimension. If slots are higher than in our standard design, spacers can be provided.

e.g. **h = 43 mm**

### Roller spacing (G) or load-bearing capacity of the bar

By changing the roller spacing the load-bearing capacity of the roller bar can be varied. Please note that the indicated load-bearing capacity applies to the complete bar length. This means that the load-bearing capacity / the roller spacing must be adapted to the die weight and the die supporting length.

Please indicate the desired roller spacing or the desired load-bearing capacity of the roller bar or the maximum die weight and the die dimensions.

e.g. **G = 60 mm**  
or **load-bearing capacity per bar = 72 kN**  
or **number of rollers = 24**  
or **die weight and outside dimensions**

### Roller bar length (L)

The possible bar length is obtained as a function of roller spacing (G) and parameter (M). Just indicate the theoretical length (e.g. the table length) for your roller bar. Please note that a roller bar must be provided with at least 3 rollers.

e.g. **L = 1445 mm**

### Roller orientation

The rollers can be orientated in the longitudinal direction of the roller bar (0° = standard) or in a crosswise direction (90°). Please indicate the orientation of the rollers required

e.g. **X = 90°**



### Selection of roller bars with standard slot height „h“ and roller spacing „G“

For other slot heights, lengths and load-bearing capacities, see range of variations page 1.

Part no.	Slot (a) (mm)	Length (L) (mm)	Max. load (kN)	Number of rollers
8.9215.7018 L 105 R	18	105	3,4	3
8.9215.7018 L 135 R	18	135	4,5	4
8.9215.7018 L 165 R	18	165	5,7	5
8.9215.7018 L 195 R	18	195	6,8	6
8.9215.7018 L 255 R	18	255	9,1	8
8.9215.7018 L 315 R	18	315	11,4	10
8.9215.7018 L 375 R	18	375	13,6	12
8.9215.7018 L 435 R	18	435	15,9	14
8.9215.7018 L 495 R	18	495	18,2	16
8.9215.7018 L 555 R	18	555	20,5	18
8.9215.7018 L 615 R	18	615	22,8	20
8.9215.7018 L 675 R	18	675	25,0	22
8.9215.7018 L 735 R	18	735	27,3	24
8.9215.7018 L 795 R	18	795	29,6	26
8.9215.7018 L 855 R	18	855	31,9	28
8.9215.7018 L 915 R	18	915	34,2	30
8.9215.7018 L 975 R	18	975	36,4	32
Other intermediate lengths up to max. 2895 are possible.				
8.9215.7018 L 2895 R	18	2895	109,4	96
Other intermediate lengths up to max. 2900 are possible.				
8.9215.7022 L 140 R	22	140	5,5	3
8.9215.7022 L 180 R	22	180	7,4	4
8.9215.7022 L 220 R	22	220	9,2	5
8.9215.7022 L 260 R	22	260	11,1	6
8.9215.7022 L 340 R	22	340	14,8	8
8.9215.7022 L 420 R	22	420	18,5	10
8.9215.7022 L 500 R	22	500	22,2	12
8.9215.7022 L 580 R	22	580	25,9	14
8.9215.7022 L 660 R	22	660	29,6	16
8.9215.7022 L 740 R	22	740	33,3	18
8.9215.7022 L 820 R	22	820	37,0	20
8.9215.7022 L 900 R	22	900	40,7	22
8.9215.7022 L 980 R	22	980	44,4	24
8.9215.7022 L 1060 R	22	1060	48,1	26
8.9215.7022 L 1140 R	22	1140	51,8	28
8.9215.7022 L 1220 R	22	1220	55,5	30
8.9215.7022 L 1300 R	22	1300	59,2	32
8.9215.7022 L 1380 R	22	1380	62,9	34
Other intermediate lengths up to max. 2900 are possible.				
8.9215.7022 L 2900 R	22	2900	133,2	72
Other intermediate lengths up to max. 2900 are possible.				
8.9215.7028 L 155 R	28	155	9	3
8.9215.7028 L 200 R	28	200	12	4
8.9215.7028 L 245 R	28	245	15	5
8.9215.7028 L 290 R	28	290	18	6
8.9215.7028 L 380 R	28	380	24	8
8.9215.7028 L 470 R	28	470	30	10
8.9215.7028 L 560 R	28	560	36	12
8.9215.7028 L 650 R	28	650	42	14
8.9215.7028 L 740 R	28	740	48	16
8.9215.7028 L 830 R	28	830	54	18
8.9215.7028 L 920 R	28	920	60	20
8.9215.7028 L 1010 R	28	1010	66	22
8.9215.7028 L 1100 R	28	1100	72	24
8.9215.7028 L 1190 R	28	1190	78	26
8.9215.7028 L 1280 R	28	1280	84	28
8.9215.7028 L 1370 R	28	1370	90	30
Other intermediate lengths up to max. 2900 are possible.				
8.9215.7028 L 2900 R	28	2900	192	64

Part no.	Slot (a) (mm)	Length (L) (mm)	Max. load (kN)	Number of rollers
8.9215.7036 L 170 R	36	170	13,5	3
8.9215.7036 L 220 R	36	220	18	4
8.9215.7036 L 270 R	36	270	22,5	5
8.9215.7036 L 320 R	36	320	27	6
8.9215.7036 L 420 R	36	420	36	8
8.9215.7036 L 520 R	36	520	45	10
8.9215.7036 L 620 R	36	620	54	12
8.9215.7036 L 720 R	36	720	63	14
8.9215.7036 L 820 R	36	820	72	16
8.9215.7036 L 920 R	36	920	81	18
8.9215.7036 L 1020 R	36	1020	90	20
8.9215.7036 L 1120 R	36	1120	99	22
8.9215.7036 L 1220 R	36	1220	108	24
8.9215.7036 L 1320 R	36	1320	117	26
8.9215.7036 L 1420 R	36	1420	126	28
Other intermediate lengths up to max. 2870 are possible.				
8.9215.7036 L 2870 R	36	2870	256,5	57
Other intermediate lengths up to max. 2895 are possible.				
8.9215.7013 L 105 R	13/16"	105	3,4	3
8.9215.7013 L 135 R	13/16"	135	4,5	4
8.9215.7013 L 165 R	13/16"	165	5,7	5
8.9215.7013 L 195 R	13/16"	195	6,8	6
8.9215.7013 L 255 R	13/16"	255	9,1	8
8.9215.7013 L 315 R	13/16"	315	11,4	10
8.9215.7013 L 375 R	13/16"	375	13,6	12
8.9215.7013 L 435 R	13/16"	435	15,9	14
8.9215.7013 L 495 R	13/16"	495	18,2	16
8.9215.7013 L 555 R	13/16"	555	20,5	18
8.9215.7013 L 615 R	13/16"	615	22,8	20
8.9215.7013 L 675 R	13/16"	675	25,0	22
8.9215.7013 L 735 R	13/16"	735	27,3	24
8.9215.7013 L 795 R	13/16"	795	29,6	26
8.9215.7013 L 855 R	13/16"	855	31,9	28
8.9215.7013 L 915 R	13/16"	915	34,2	30
8.9215.7013 L 975 R	13/16"	975	36,4	32
Other intermediate lengths up to max. 2895 are possible.				
8.9215.7013 L 2895 R	13/16"	2895	109,4	96
Other intermediate lengths up to max. 2900 are possible.				
8.9215.7017 L 140 R	1 1/16"	140	5,5	3
8.9215.7017 L 180 R	1 1/16"	180	7,4	4
8.9215.7017 L 220 R	1 1/16"	220	9,2	5
8.9215.7017 L 260 R	1 1/16"	260	11,1	6
8.9215.7017 L 340 R	1 1/16"	340	14,8	8
8.9215.7017 L 420 R	1 1/16"	420	18,5	10
8.9215.7017 L 500 R	1 1/16"	500	22,2	12
8.9215.7017 L 580 R	1 1/16"	580	25,9	14
8.9215.7017 L 660 R	1 1/16"	660	29,6	16
8.9215.7017 L 740 R	1 1/16"	740	33,3	18
8.9215.7017 L 820 R	1 1/16"	820	37,0	20
8.9215.7017 L 900 R	1 1/16"	900	40,7	22
8.9215.7017 L 980 R	1 1/16"	980	44,4	24
8.9215.7017 L 1060 R	1 1/16"	1060	48,1	26
8.9215.7017 L 1140 R	1 1/16"	1140	51,8	28
8.9215.7017 L 1220 R	1 1/16"	1220	55,5	30
8.9215.7017 L 1300 R	1 1/16"	1300	59,2	32
8.9215.7017 L 1380 R	1 1/16"	1380	62,9	34
Other intermediate lengths up to max. 2900 are possible.				
8.9215.7017 L 2900 R	1 1/16"	2900	133,2	72

▼  
R = fastening plate  
K = wedge lock

# Roller bar with spring pack

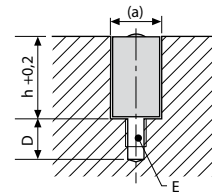
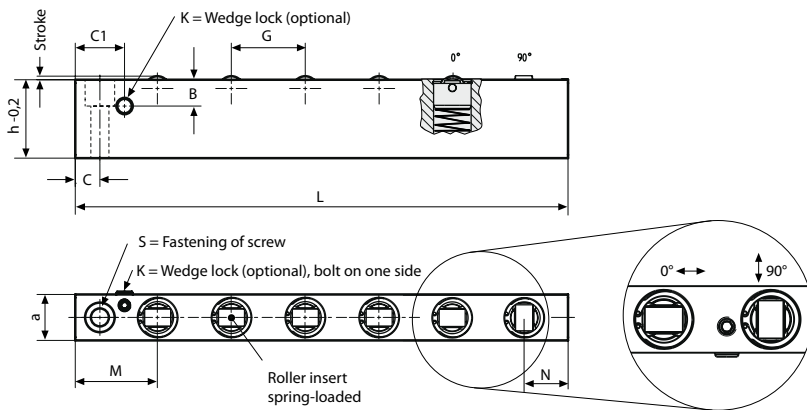

Optional extra: Roller turned through 90°

### Roller orientation

The load-bearing rollers can be mounted in the longitudinal direction of the roller bar (0° = standard) as well as in a crosswise direction (90°). Please indicate the direction of the roller, e.g. **X = 90°**

**Tmax.: 100°C**

Higher temperatures on request

Slot a (mm)	18	22	28	36	13/16"	1 1/16"
Slot height min. (h) (mm)	28,5	34,5	42	51,5	28,5	34,5
Standard slot height (h) (mm)	30	38	48	61	29,4	38,9
<b>Roller spacing G min. (mm)</b>	20	23	28	34	20	23
Standard roller spacing G (mm)	<b>30</b>	<b>40</b>	<b>45</b>	<b>50</b>	<b>30</b>	<b>40</b>
Roller spacing G max. (mm)	60	80	90	100	60	80
L min. (mm)	*)	*)	*)	*)	*)	*)
L max. (mm)	2900	2900	2900	2900	2900	2900
Stroke (mm)	1	2	2	2	1	2
Load-bearing capacity (kN)	0,6	0,9	1,4	2,4	0,6	0,9
B (mm)	12	16	16	16	12	16
C (mm)	10	12,5	15	20	10	12,5
C1 (mm)	10	24,5	30	35	10	24,5
D (mm)	15	15	20	20	15	15
E (mm)	M6	M8	M10	M10	M6	M8
M (mm)	27,5	40	50	57,5	27,5	40
N (mm)	12,5	15	25	27,5	12,5	15

\*) L min. Depends on roller spacing G with at least 3 rollers

Load-bearing capacity indicated per roller bar;

Suffix K = wedge lock; S = fastening plate

## Example of ordering:

**8.9216.7036 L1385 K** without suffix  
 Roller bar, Slot Length Standard Standard Standard roller  
 spring-loaded 36 mm 1385 mm slot height roller spacing orientation (0°)  
 Fastening of wedge lock

## Example of ordering:

**8.9216.7036 L1380 S H52 G35 X**  
 Roller bar, Slot Length Slot height Roller Roller orientation  
 spring-loaded 36 mm 1380 mm 52 mm spacing of 90°  
 Fastening of screw

S = fastening of screw

K = wedge lock

By means of these parameters we will determine the roller bar for your specific application. Please contact us, we will be pleased to give you any advice you may require.

## Roller bar variations with spring pack

If the appropriate roller bar for your specific application is not included in the table of standard bars, our range of variations offers a solution.

Fewer rollers also means that the roller bar will be offered at a lower price. Select the slot height, the roller spacing and the bar length to create the correct variation for your application.

## Within the limits stated in the table of dimensions, the following parameters can be freely selected:

### Slot height (h)

If, in your application, the slot height does not correspond to our standard design, please indicate the required dimension. If slots are higher than in our standard design, spacers can be provided

e.g. **h = 45 mm**

### Roller spacing (G) or load-bearing capacity of the bar

By changing the roller spacing the load-bearing capacity of the roller bar can be varied.

Please note that the indicated load-bearing capacity applies to the complete bar length. This means that the load-bearing capacity / the roller spacing must be adapted to the die weight and the die supporting length. Please indicate the desired roller spacing or the desired load-bearing capacity of the roller bar or the maximum die weight and the die dimensions.

e.g. **G = 35 mm**

or **load-bearing capacity per bar 92.1 kN**

or **number of rollers = 38**

or **die weight and outside dimension**

### Roller bar length (L)

The possible bar length is obtained as a function of roller spacing (G) and parameter (M). Just indicate the theoretical length (e.g. the table length) for your roller bar. Please note that a roller bar must be provided with at least 3 rollers.

e.g. **L = 1380 mm**

### Roller orientation

The rollers can be orientated in longitudinal direction of the roller bar (0° = standard) or in crosswise direction (90°). Please indicate the orientation of the rollers

e.g. **X = 90°**



### Selection of roller bars with standard slot height „h“ and roller spacing „G“

For other slot heights, lengths and load-bearing capacities, see range of variations page 1.

Part no.	Slot (a) (mm)	Length (L) (mm)	Max. load (kN)	Number of rollers
8.9216.7018 L 100 S	18	100	1,8	3
8.9216.7018 L 130 S	18	130	2,4	4
8.9216.7018 L 160 S	18	160	3	5
8.9216.7018 L 190 S	18	190	3,6	6
8.9216.7018 L 250 S	18	250	4,8	8
8.9216.7018 L 310 S	18	310	6	10
8.9216.7018 L 370 S	18	370	7,2	12
8.9216.7018 L 430 S	18	430	8,4	14
8.9216.7018 L 490 S	18	490	9,6	16
8.9216.7018 L 550 S	18	550	10,8	18
8.9216.7018 L 610 S	18	610	12	20
8.9216.7018 L 670 S	18	670	13,2	22
8.9216.7018 L 730 S	18	730	14,4	24
Other intermediate lengths up to max. 2890 are possible.				
8.9216.7018 L 2890 S	18	2890	57,6	96
8.9216.7022 L 135 S	22	135	2,7	3
8.9216.7022 L 175 S	22	175	3,6	4
8.9216.7022 L 215 S	22	215	4,5	5
8.9216.7022 L 255 S	22	255	5,4	6
8.9216.7022 L 335 S	22	335	7,2	8
8.9216.7022 L 415 S	22	415	9	10
8.9216.7022 L 495 S	22	495	10,8	12
8.9216.7022 L 575 S	22	575	12,6	14
8.9216.7022 L 655 S	22	655	14,4	16
8.9216.7022 L 735 S	22	735	16,2	18
8.9216.7022 L 815 S	22	815	18	20
8.9216.7022 L 895 S	22	895	19,8	22
8.9216.7022 L 975 S	22	975	21,6	24
8.9216.7022 L 1055 S	22	1055	23,4	26
8.9216.7022 L 1135 S	22	1135	25,2	28
8.9216.7022 L 1215 S	22	1215	27	30
8.9216.7022 L 1295 S	22	1295	28,8	32
Other intermediate lengths up to max. 2895 are possible.				
8.9216.7022 L 2895 S	22	2895	64,8	72
8.9216.7028 L 165 S	28	165	4,2	3
8.9216.7028 L 210 S	28	210	5,6	4
8.9216.7028 L 255 S	28	255	7	5
8.9216.7028 L 300 S	28	300	8,4	6
8.9216.7028 L 390 S	28	390	11,2	8
8.9216.7028 L 480 S	28	480	14	10
8.9216.7028 L 570 S	28	570	16,8	12
8.9216.7028 L 660 S	28	660	19,6	14
8.9216.7028 L 750 S	28	750	22,4	16
8.9216.7028 L 840 S	28	840	25,2	18
8.9216.7028 L 930 S	28	930	28	20
8.9216.7028 L 1020 S	28	1020	30,8	22
Other intermediate lengths up to max. 2865 are possible.				
8.9216.7028 L 2865 S	28	2865	88,2	63

Part no.	Slot (a) (mm)	Length (L) (mm)	Max. load (kN)	Number of rollers
8.9216.7036 L 185 S	36	185	7,2	3
8.9216.7036 L 235 S	36	235	9,6	4
8.9216.7036 L 285 S	36	285	12	5
8.9216.7036 L 335 S	36	335	14,4	6
8.9216.7036 L 435 S	36	435	19,2	8
8.9216.7036 L 535 S	36	535	24	10
8.9216.7036 L 635 S	36	635	28,8	12
8.9216.7036 L 735 S	36	735	33,6	14
8.9216.7036 L 835 S	36	835	38,4	16
8.9216.7036 L 935 S	36	935	43,2	18
8.9216.7036 L 1035 S	36	1035	48	20
8.9216.7036 L 1135 S	36	1135	52,8	22
Other intermediate lengths up to max. 2885 are possible.				
8.9216.7036 L 2985 S	36	2885	136,8	57
8.9216.7013 L 100 S	13/16"	100	1,8	3
8.9216.7013 L 130 S	13/16"	130	2,4	4
8.9216.7013 L 160 S	13/16"	160	3	5
8.9216.7013 L 190 S	13/16"	190	3,6	6
8.9216.7013 L 250 S	13/16"	250	4,8	8
8.9216.7013 L 310 S	13/16"	310	6	10
8.9216.7013 L 370 S	13/16"	370	7,2	12
8.9216.7013 L 430 S	13/16"	430	8,4	14
8.9216.7013 L 490 S	13/16"	490	9,6	16
8.9216.7013 L 550 S	13/16"	550	10,8	18
8.9216.7013 L 610 S	13/16"	610	12	20
8.9216.7013 L 670 S	13/16"	670	13,2	22
8.9216.7013 L 730 S	13/16"	730	14,4	24
Other intermediate lengths up to max. 2890 are possible.				
8.9216.7013 L 2890 S	13/16"	2890	57,6	96
8.9216.7017 L 135 S	1 1/16"	135	2,7	3
8.9216.7017 L 175 S	1 1/16"	175	3,6	4
8.9216.7017 L 215 S	1 1/16"	215	4,5	5
8.9216.7017 L 255 S	1 1/16"	255	5,4	6
8.9216.7017 L 335 S	1 1/16"	335	7,2	8
8.9216.7017 L 415 S	1 1/16"	415	9	10
8.9216.7017 L 495 S	1 1/16"	495	10,8	12
8.9216.7017 L 575 S	1 1/16"	575	12,6	14
8.9216.7017 L 655 S	1 1/16"	655	14,4	16
8.9216.7017 L 735 S	1 1/16"	735	16,2	18
8.9216.7017 L 815 S	1 1/16"	815	18	20
8.9216.7017 L 895 S	1 1/16"	895	19,8	22
8.9216.7017 L 975 S	1 1/16"	975	21,6	24
8.9216.7017 L 1055 S	1 1/16"	1055	23,4	26
8.9216.7017 L 1135 S	1 1/16"	1135	25,2	28
8.9216.7017 L 1215 S	1 1/16"	1215	27	30
8.9216.7017 L 1295 S	1 1/16"	1295	28,8	32
Other intermediate lengths up to max. 2895 are possible.				
8.9216.7017 L 2895 S	1 1/16"	2895	64,8	72

▼  
S = screw  
K = wedge lock



**Roller insert**



without flange

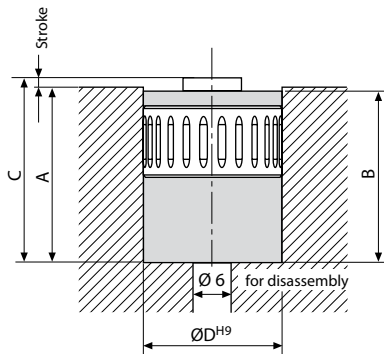

**Design without flange**

Max. load (N)	600	900	1400	2400
*Stroke (mm)	1,5	2,0	2,0	2,0
A (mm)	30,0 +0,1	32,0 +0,1	43,5 +0,1	52,5 +0,1
B (mm)	29,9	31,9	43,4	52,4
C (mm)	31,5	34,0	45,5	54,5
Ø D (mm)	20	24	30	40
<b>Part no.</b>	<b>8.1210.0605</b>	<b>8.1210.0611</b>	<b>8.1210.0618</b>	<b>8.1210.0622</b>

\* Other strokes available on request



with flange

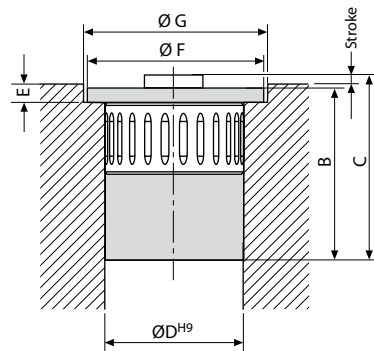

**Design with flange**

Max. load (N)	600	900	1400	2400
*Stroke (mm)	1,5	2,0	2,0	2,0
B (mm)	29,9 +0,1	31,9 +0,1	43,4 +0,1	52,4 +0,1
C (mm)	31,5	34,0	45,5	54,5
Ø D (mm)	20	24	30	40
E (mm)	3,5 +0,1	3,5 +0,1	4,5 +0,1	5,5 +0,1
Ø F (mm)	24,5	29,5	34,5	47,5
Ø G (mm)	25 +0,2	30 +0,2	35 +0,2	48 +0,2
<b>Part no.</b>	<b>8.1210.0606</b>	<b>8.1210.0612</b>	<b>8.1210.0619</b>	<b>8.1210.0623</b>

\* Other strokes available on request

**Ball insert**



without flange

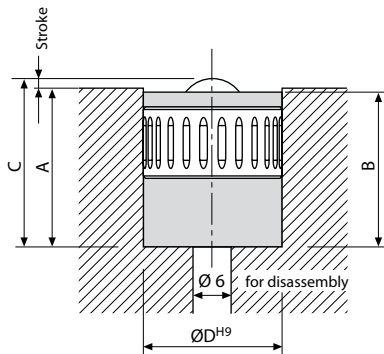

**Design without flange**

Max. load (N)	200	400	600	1000
*Stroke (mm)	1,5	1,5	2,0	3,0
A (mm)	24,0 +0,1	28,5 +0,1	34,0 +0,1	45,0 +0,1
B (mm)	23,6	28,5	34,0	44,8
C (mm)	25,5	30,0	36,0	48,0
Ø D (mm)	20	24	30	40
<b>Part no.</b>	<b>8.1210.0005</b>	<b>8.1210.0011</b>	<b>8.1210.0018</b>	<b>8.1210.0022</b>

\* Other strokes available on request



with flange

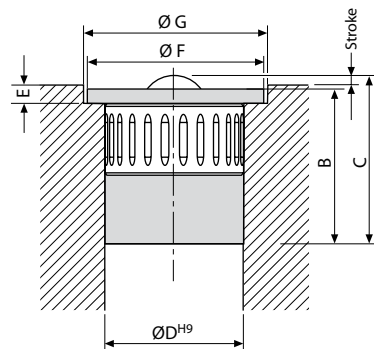

**Design with flange**

Max. load (N)	200	400	600	1000
*Stroke (mm)	1,5	1,5	2,0	2,0
B (mm)	23,5	28,5	34,0	44,0
C (mm)	25,2	30,2	36,0	46,0
Ø D (mm)	20	24	30	40
E (mm)	3,5 +0,1	4,0 +0,1	4,5 +0,1	5,6 +0,1
Ø F (mm)	24,5	29,5	34,5	47,5
Ø G (mm)	25 +0,2	30 +0,2	35 +0,2	48 +0,2
<b>Part no.</b>	<b>8.1210.0006</b>	<b>8.1210.0012</b>	<b>8.1210.0019</b>	<b>8.1210.0023</b>

\* Other strokes available on request