

## Carrying consoles

for easy and efficient die change on the press bed

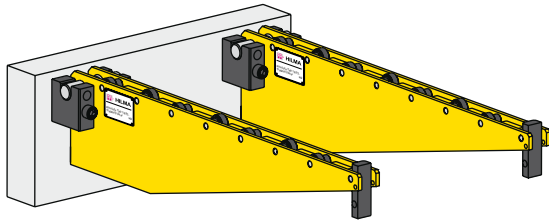

# HILMA



Colour: RAL 1004, golden yellow

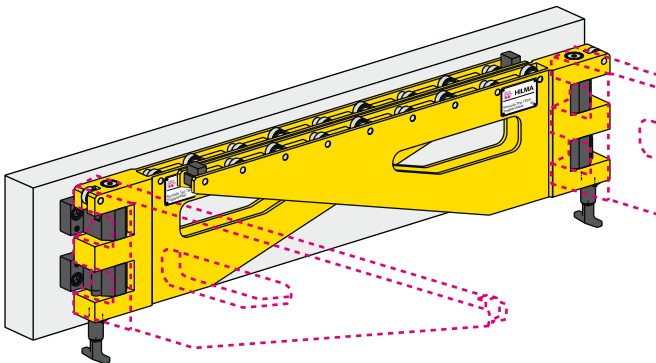
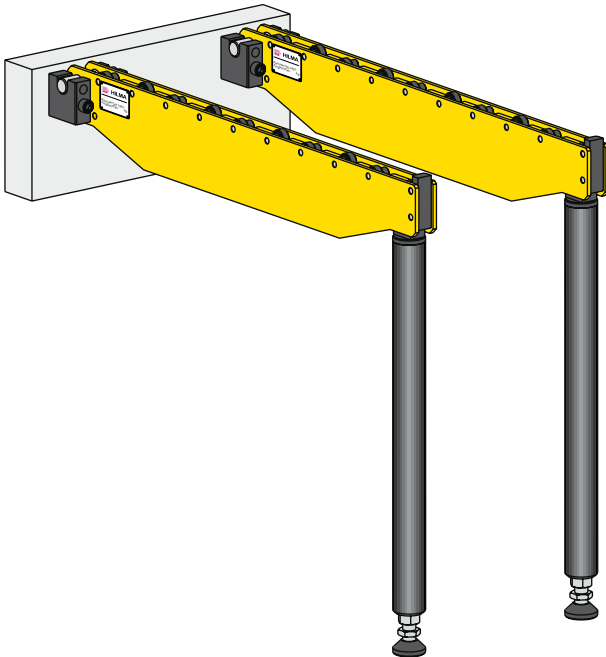

### Carrying console, hanging

The carrying consoles are hung in the hooks on the die changing side of the press. The hooks are supplied with the consoles. The consoles are used as a pair only. Their size must be selected to suit the highest die weight.

The die is loaded onto the consoles using a crane or a forklift truck.

The carrying rollers consist of high-strength hardened needle bearings. The end stop can be bypassed in one direction only.

The surface is provided with a shock-resistant coating in RAL 1004, golden yellow.

Hanging consoles may be used for several presses. In this case, an additional set of hooks is required.

### Carrying console, supported

In order to cope with heavy and large dies, the hanging console is provided with an additional support.

For compensating for unevenness on the floor, the supports are designed as adjustable supports with a ball-and-socket joint. The height may be changed subsequently by  $\pm 60$  mm.

The end stop can be bypassed in one direction only.

### Carrying console, swivelling

This console is permanently fastened to the press bed and can be pivoted into the die changing position.

This type is particularly recommended when the available space in front of the press bed is limited, or if removal and intermediate storage of the console is not possible or required.

For carrying rollers, end stop and surface coating, see above.

**Special designs of carrying consoles are available on request.**

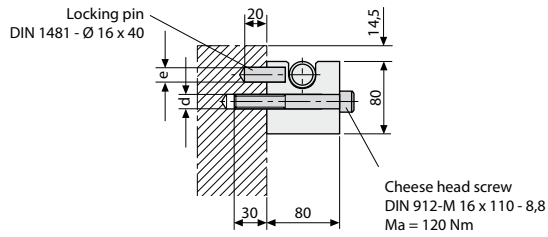

### Hole pattern

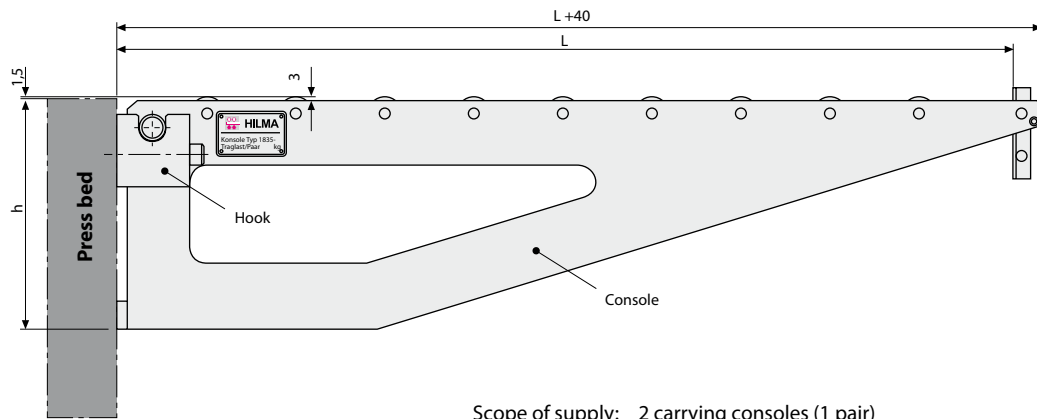
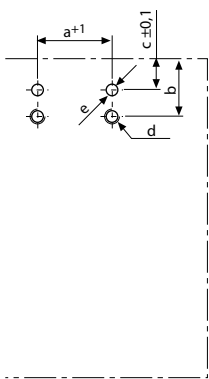

Scope of supply: 2 carrying consoles (1 pair)  
4 hooks

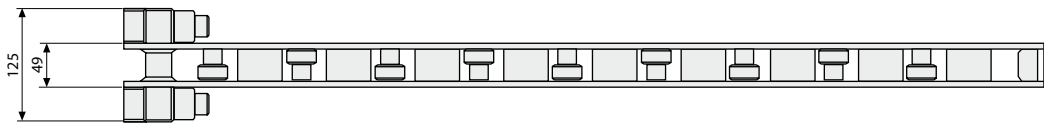

Part no. for 1 pair	Max. load/ pair (kN)	Length of support (L) (mm)	Dimensions (mm)						Weight pair (kg)
			a+1	b	c <sup>±0,1</sup>	d		h	
<b>8.1835.0001</b>	5	500	86	60	30	M16	Ø16	120	15
➤ <b>8.1835.0002</b>	10	500	86	60	30	M16	Ø16	150	18
<b>8.1835.0003</b>	10	800	86	60	30	M16	Ø16	180	30
➤ <b>8.1835.0104</b>	10	1000	86	60	30	M16	Ø16	250	40
<b>8.1835.0105</b>	20	800	86	60	30	M16	Ø16	250	32
➤ <b>8.1835.0006</b>	20	1000	86	60	30	M16	Ø16	300	48
<b>8.1835.0107</b>	20	1250	86	60	30	M16	Ø16	350	70
<b>8.1835.0008</b>	30	800	86	60	30	M16	Ø16	400	48
➤ <b>8.1835.0009</b>	30	1000	86	60	30	M16	Ø16	450	66
<b>8.1835.0010</b>	30	1250	86	60	30	M16	Ø16	500	90

4 hooks are supplied with the consoles

➤ available at short notice

1 additional set of hooks (= 4 OFF)  
**part no. 7.1835.0007** (40 kN)

# Carrying console, supported



## Console 20 - 40 kN

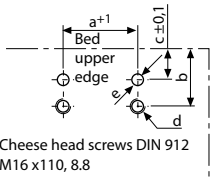

Cheese head screws DIN 912  
M16 x110, 8.8  
 $M_s = 120 \text{ Nm}$   
Locking pin DIN 1481  $\varnothing 16 \times 40$

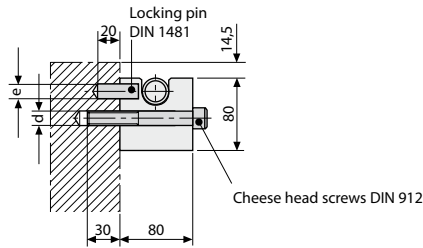

## Console 60 - 100 kN

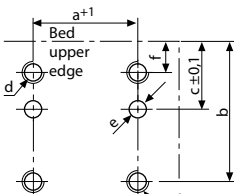

Cheese head screws DIN 912  
M16 x 50 und M16 x 110  
 $M_s = 120 \text{ Nm}$   
Locking pin DIN 1481  $\varnothing 16 \times 50$

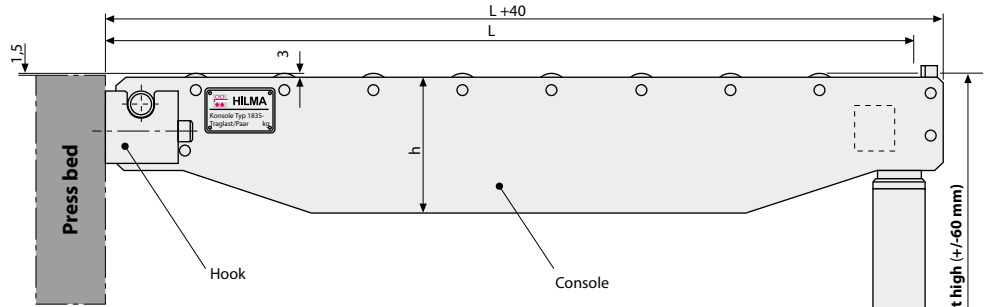

## Console 160 - 250 kN

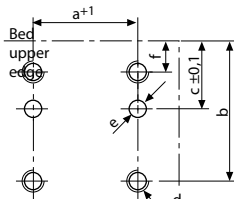

Cheese head screws DIN 912  
M24 x 80 und M24 x 160  
 $M_s = 250 \text{ Nm}$   
Locking pin DIN 1481  $\varnothing 20 \times 100$

**When ordering, please specify the exact height of support**

Scope of supply: 2 carrying consoles (1 pair)  
4 hooks  
2 supporting feet

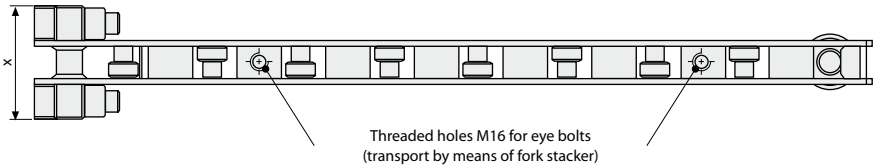
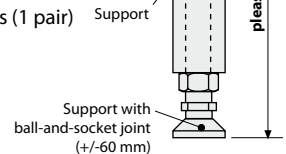

Part no. for 1 pair	Max. load pair (kN)	Length of support (L) (mm)	Dimensions (mm)								Weight pair (kg)
			a+1	b	c <sup>±0.1</sup>	d	e	f	h	x	
8.1835.3001	20	1000	86	60	30	M16	Ø16	-	150	125	60
8.1835.3102	20	1250	86	60	30	M16	Ø16	-	180	125	80
8.1835.3003	20	1600	86	60	30	M16	Ø16	-	200	125	100
➤ 8.1835.3204	40	1000	86	60	30	M16	Ø16	-	200	125	70
➤ 8.1835.3205	40	1250	86	60	30	M16	Ø16	-	200	125	85
8.1835.3206	40	1600	86	60	30	M16	Ø16	-	225	125	110
8.1835.3209	60	1000	91	105	45	M16	Ø16	20	200	125	75
8.1835.3210	60	1250	91	105	45	M16	Ø16	20	220	125	90
➤ 8.1835.3211	60	1600	91	105	45	M16	Ø16	20	240	125	120
8.1835.3212	60	2000	91	105	45	M16	Ø16	20	270	125	170
8.1835.3213	100	1250	91	105	45	M16	Ø16	20	250	125	100
8.1835.3214	100	1600	91	105	45	M16	Ø16	20	280	125	140
8.1835.3215	100	2000	91	105	45	M16	Ø16	20	320	125	180
8.1835.3216	160	1600	160	145	75	M24	Ø20	30	260	210	240
8.1835.3217	160	2000	160	145	75	M24	Ø20	30	260	210	330
8.1835.3218	160	2500	160	145	75	M24	Ø20	30	280	210	480
8.1835.3220	250	2500	160	145	75	M24	Ø20	30	360	210	540

4 hooks and 2 supports are supplied with the consoles  
➤ available at short notice

**Example for ordering: 8.1835.3001, SH 1000**  
console 1000 mm long  
max. 20 kN  
height of support 1000 mm

1 additional set of hooks (= 4 OFF)  
**part no. 7.1835.0007** (40 kN),  
**part no. 7.1835.0021** (100 kN),  
**part no. 7.1835.0022** (250 kN)

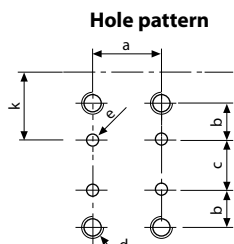

Cheese head screws DIN 912  
M16 x 40, 8.8  
 $M_t = 120 \text{ Nm}$   
Locking pin DIN 1481  $\varnothing 10 \times 50$

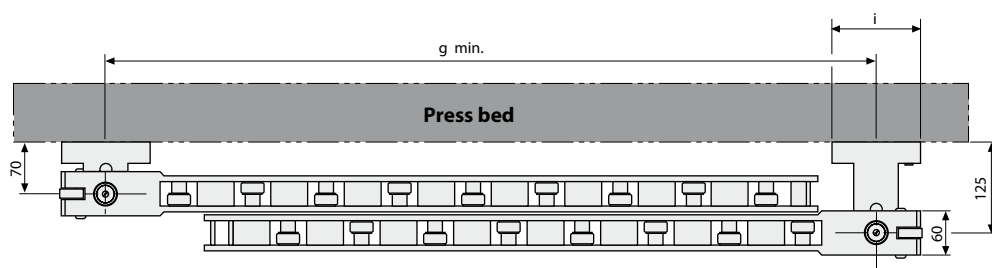
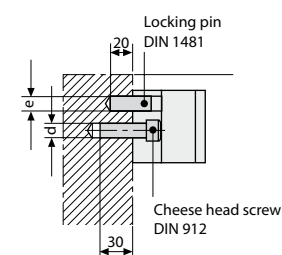
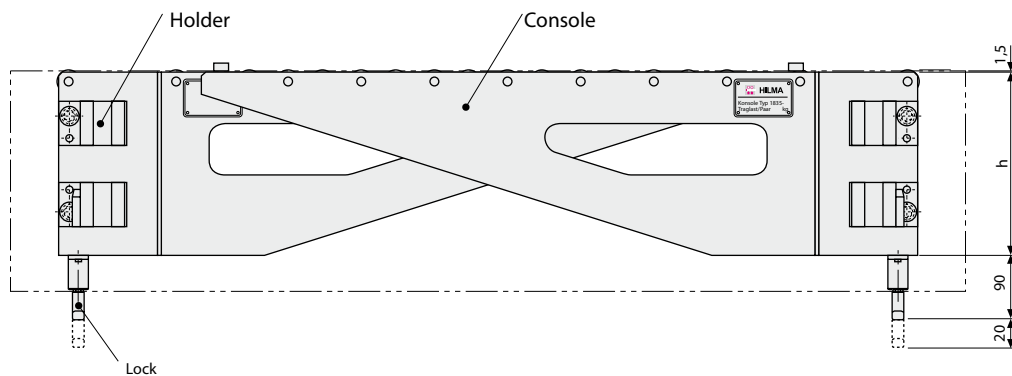

Scope of supply: 2 carrying consoles (left and right side)  
4 holders (premounted)

### The carrying console is swivelling on the left and right side

Part no. for 1 pair	Max. load pair (kN)	Length of support (L) (mm)	Dimensions (mm)								
			$a^{\pm 0,2}$	$b^{\pm 0,1}$	$c^{\pm 0,1}$	d	e	g	h	i	$k^{\pm 0,1}$
8.1835.1001	10	500	90	30	20	M16	$\varnothing 10$	550	200	120	91,5
8.1835.1002	10	1000	90	30	70	M16	$\varnothing 10$	1050	250	120	91,5
8.1835.1003	20	1000	90	30	120	M16	$\varnothing 10$	1050	300	120	91,5
8.1835.1004	20	1250	90	30	170	M16	$\varnothing 10$	1300	350	120	91,5
8.1835.1105	40	1000	90	30	210	M16	$\varnothing 10$	1050	450	120	121,5
8.1835.1106	40	1250	90	30	260	M16	$\varnothing 10$	1300	500	120	121,5
8.1835.1107	60	1000	90	30	310	M16	$\varnothing 10$	1050	550	120	121,5
8.1835.1108	60	1250	90	30	460	M16	$\varnothing 10$	1300	700	120	121,5

Carrying consoles are supplied in pairs with holders fastened, ready for connection  
Special designs and double-swivel consoles are available on request.

### Special designs of carrying consoles, e.g. sliding carrying console, are available on request



## Die changing station with drive

Dies up to a weight of 200 kN



# HILMA



### Die changing system directly adapted to the press

This new die changing system with special pushpull drive makes handling of dies easier and ensures time-saving and accident-free movement of dies with a maximum weight of 10 tons in places difficult to access.

(Higher load-bearing capacities on request)

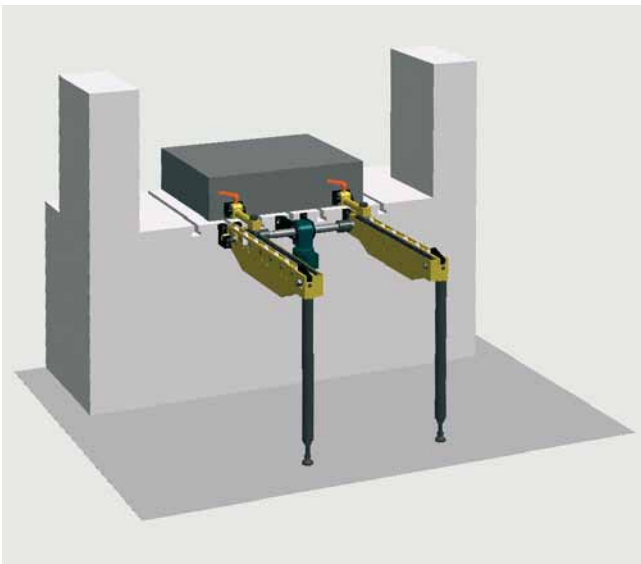

Roller and ball bars in the T-slots of the table provide for easy insertion of the die, either manually or automatically. Damage to the die causing production loss is avoided. Individual solutions including automatic die changing and integration in the press are possible.

### Description:

The cost-effective drive system has been developed on the basis of standard die consoles and can be easily installed as it requires only little space. Thus, it is very suitable for both retrofitting and new constructions.

The drive unit and the carrying console are hung in hooks provided on the press for this purpose and then locked. The die is deposited on the consoles using a crane or a forklift truck. After the die has been deposited, it can be connected to the changing station by means of a push-and-pull system.

The integral chain drive system allows the user automatic die loading and positioning, just by depressing a pushbutton on a separate remote control pendant.

During a die change, the press bed is free, i.e. the push-and-pull elements do not project over the press bed. Furthermore the rear side of the press is completely free. This changing station is suitable for almost any press, can be easily removed and is easy to handle.

### Special features:

Besides the reduction of non-productive set-up time, the die changing system offers further decisive

### benefits to the user:

- ◆ maximization of profits due to less downtime
- ◆ smaller production batches are possible due to shorter set-up times
- ◆ greater safety for man and machine
- ◆ safe and accident-free handling of dies with less effort, thus creating a more humanised place of work





### Variations of the die changing station

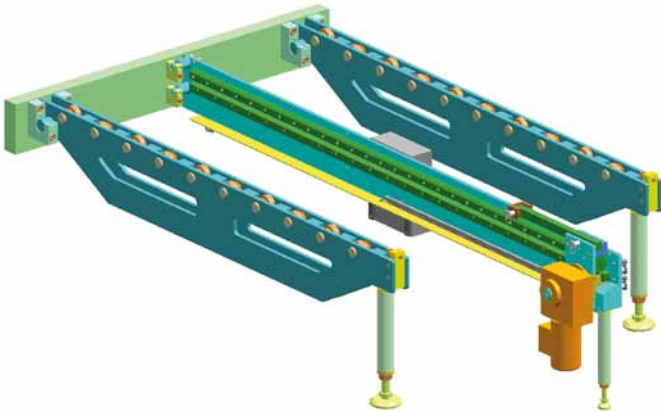

Variation with a driven central console and two standard-type carrying consoles on the right and left side. This cost-effective alternative is flexible and can be used on various presses.

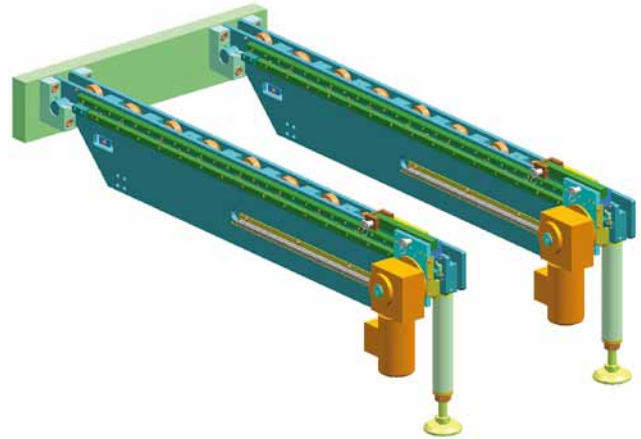

Variation with two driven and synchronized consoles. This extremely robust and precise alternative is suitable for almost all dies and geometries.